

# *PROMINP: O&G Brazilian Industry Mobilization Program*

*Houston Aug, 30th 2011*



Ministério de  
Minas e Energia



ABCE - ABDIB - ABEMI - ABIMAQ - ABINEE - ABITAM - BNDES - CNI - IBP - ONIP - SINAVAL

## PROMINP's Objective



“Maximize goods and services **national industry** content, within **competitive** and **sustainable** basis, in the implantation of oil and gas projects in Brazil and abroad.”

# PROMINP Management Structure



**MME** – Minister  
**MDIC** – Minister  
**PETROBRAS** – President and Services Director  
**ONIP** – CEO/President  
**BNDES** – President  
**IBP** – President



**MME** – Oil, Natural Gas and Renewable Fuels Secretariat  
**MDIC** – Development, Industry and International Trade Secretariat  
**BNDES** - Director  
**PETROBRAS** – Engineering Executive Manager  
**PROMINP** – Executive Coordinator  
**ONIP** – Director  
**IBP** – Director  
**Associations** – President / Director (ABCE, ABDIB, ABEMI, ABIMAQ, ABINEE, ABITAM SINAVAL e CNI)

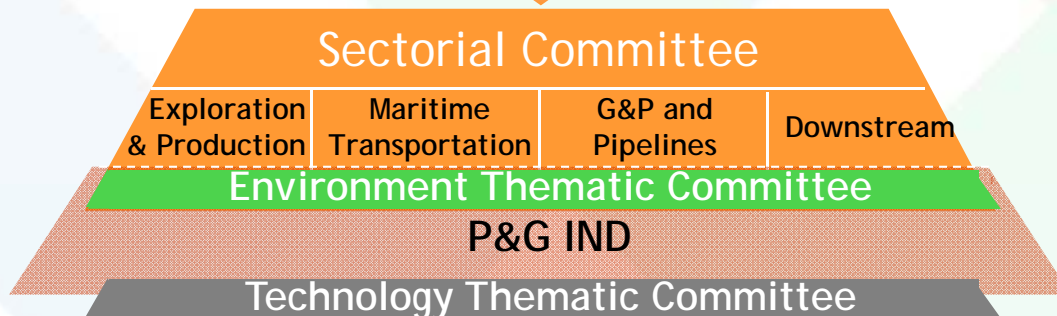

# Petrobras Investments in Brazil



*Business Plan x Petrobras Investments*

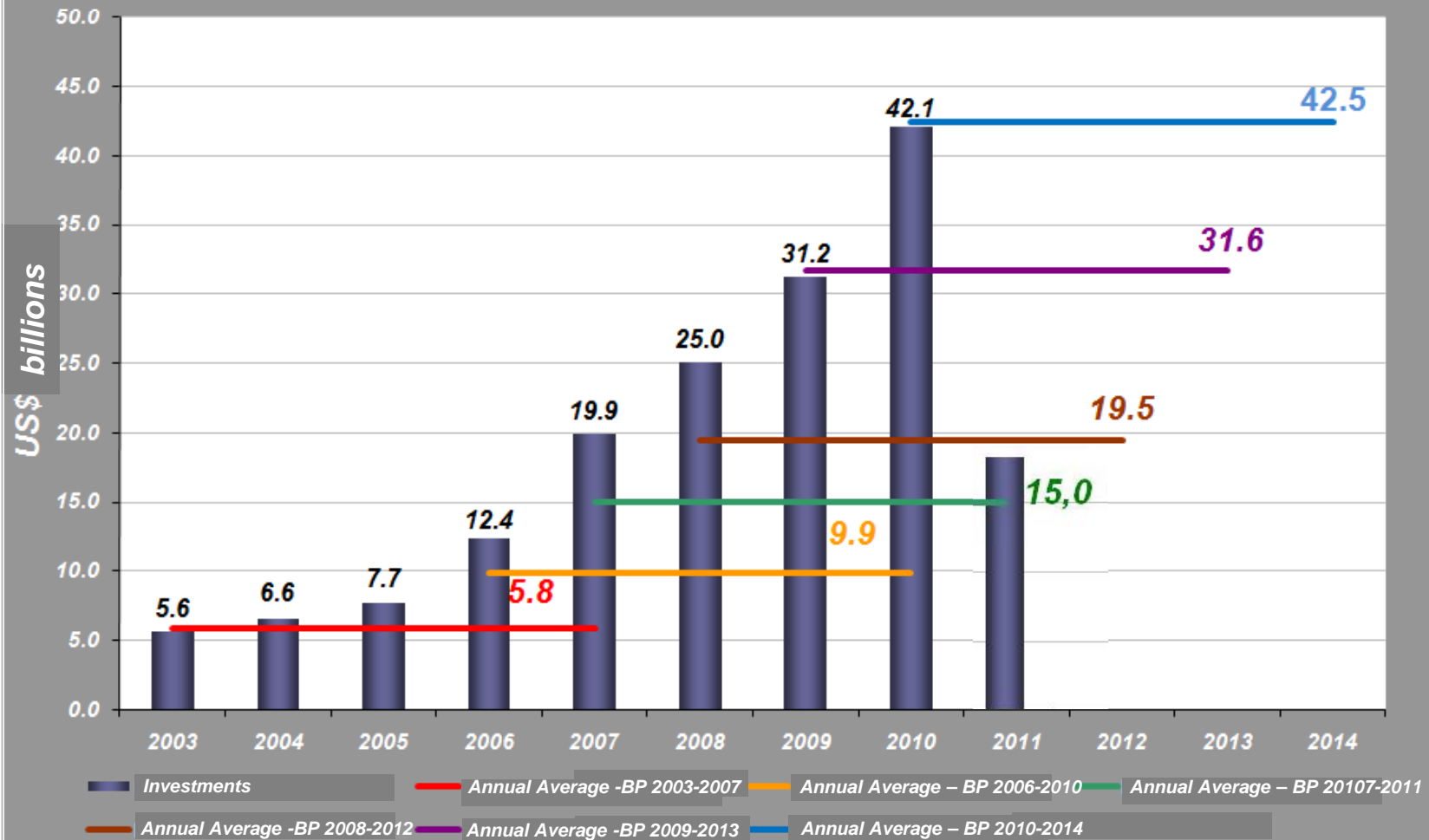

Source: Petrobras

# Strategic Subjects



**CHALLENGE**  
Maximize Local  
Content

## Strategic Subjects

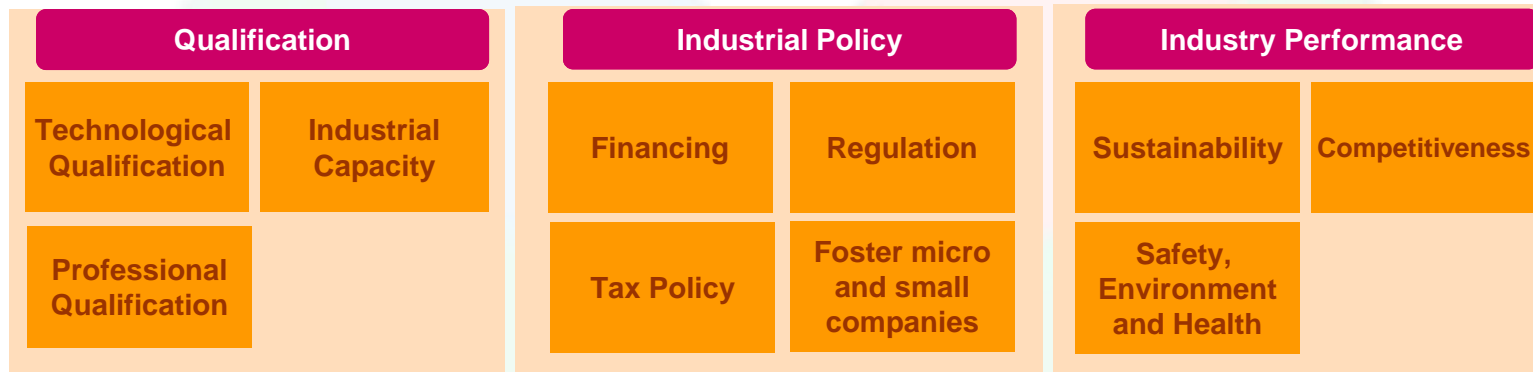

## Prominp Projects Portfolio

E&P

Maritime  
Transportation

Downstream

GP&Pipelines

O&G IND

Environment

Technology

# Projects Portfolio: Exploration & Production



- BP 2003 - 2007
- BP 2004 - 2010
- BP 2007- 2011
- BP 2008 - 2012
- BP 2009 - 2013

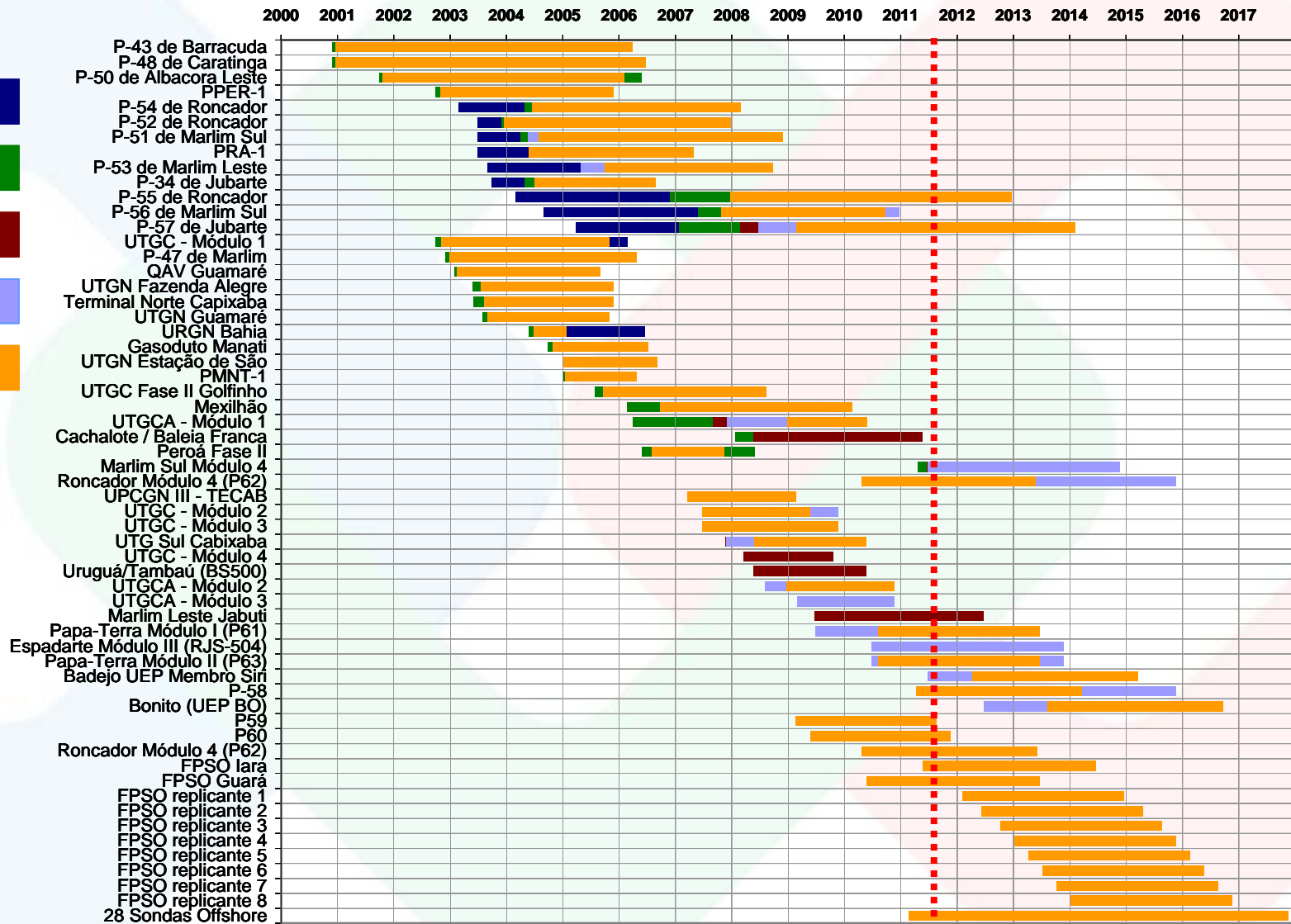

BP – Business Plan

# Projects Portfolio: Refining & Petrochemical



2000 2001 2002 2003 2004 2005 2006 2007 2008 2009 2010 2011 2012 2013 2014 2015 2016 2017

- BP 2003- 2007
- BP 2004 - 2010
- BP 2007- 2011
- BP 2008 - 2012
- BP 2009 - 2013

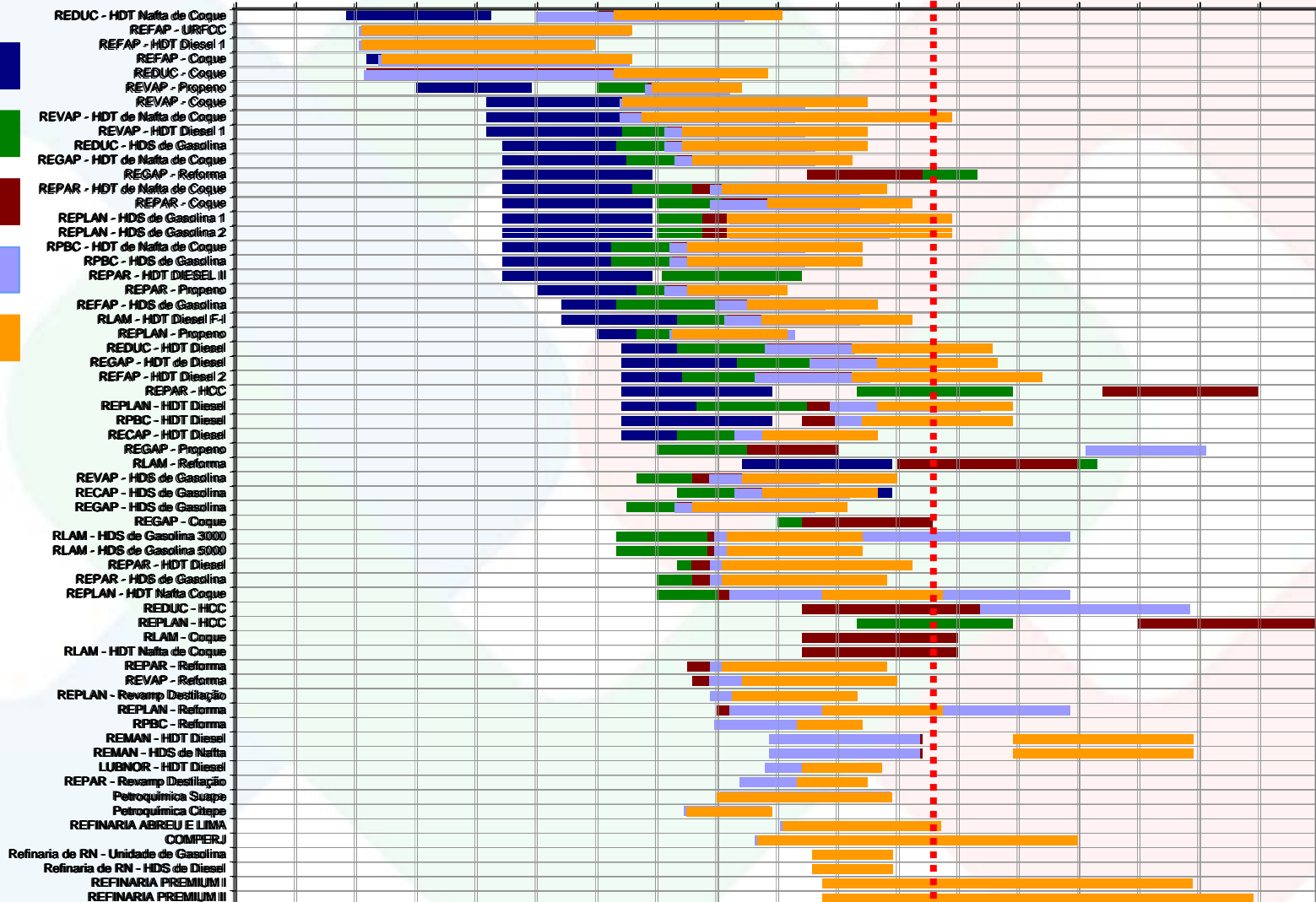

# Projects Portfolio: Gas, Power and Pipelines



2000 2001 2002 2003 2004 2005 2006 2007 2008 2009 2010 2011 2012 2013 2014 2015 2016 2017

- BP 2003 - 2007**
- BP 2004 - 2010**
- BP 2007- 2011**
- BP 2008 - 2012**
- BP 2009 - 2013**

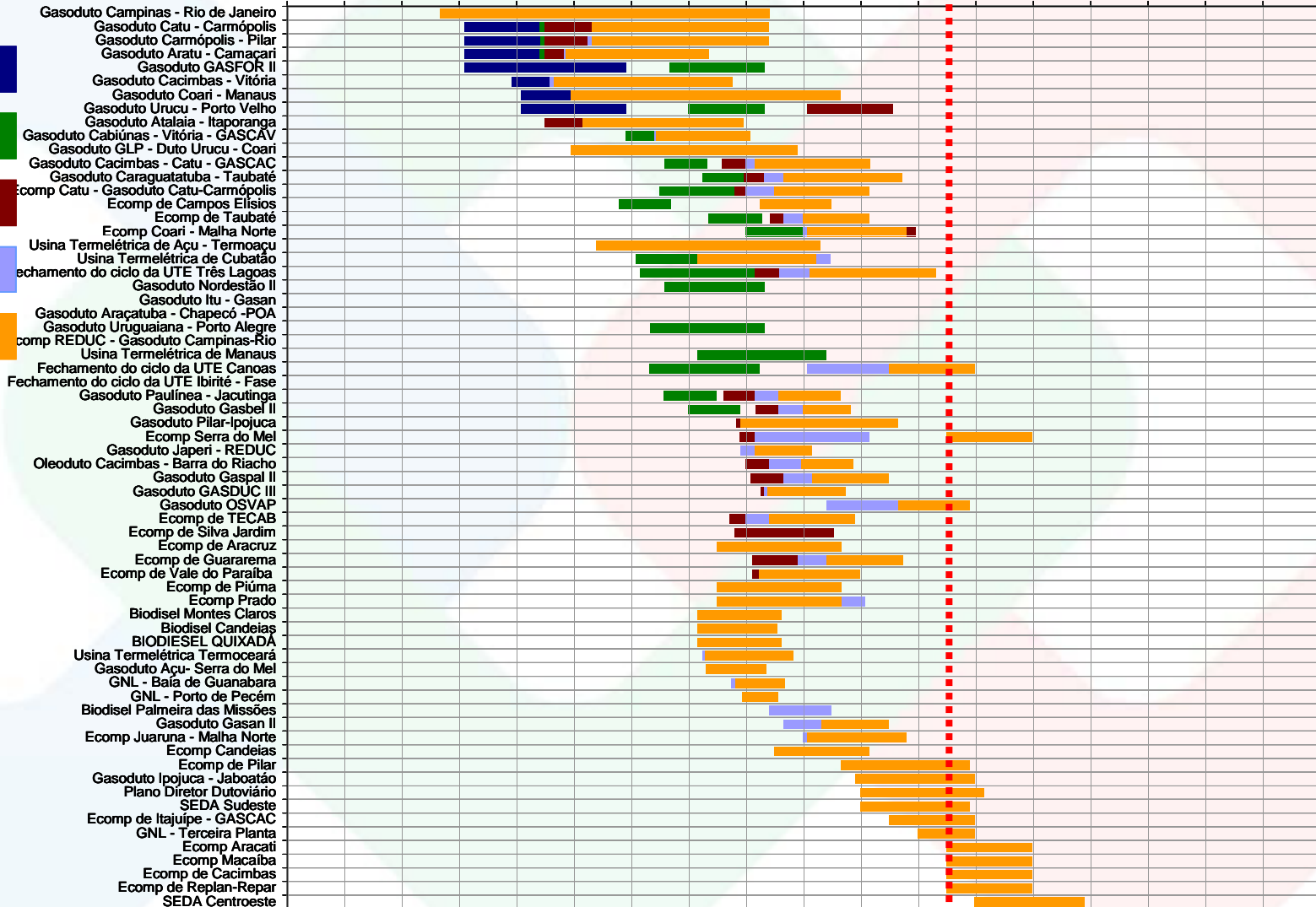

BP – Business Plan

# Projects Portfolio: Maritime Transportation

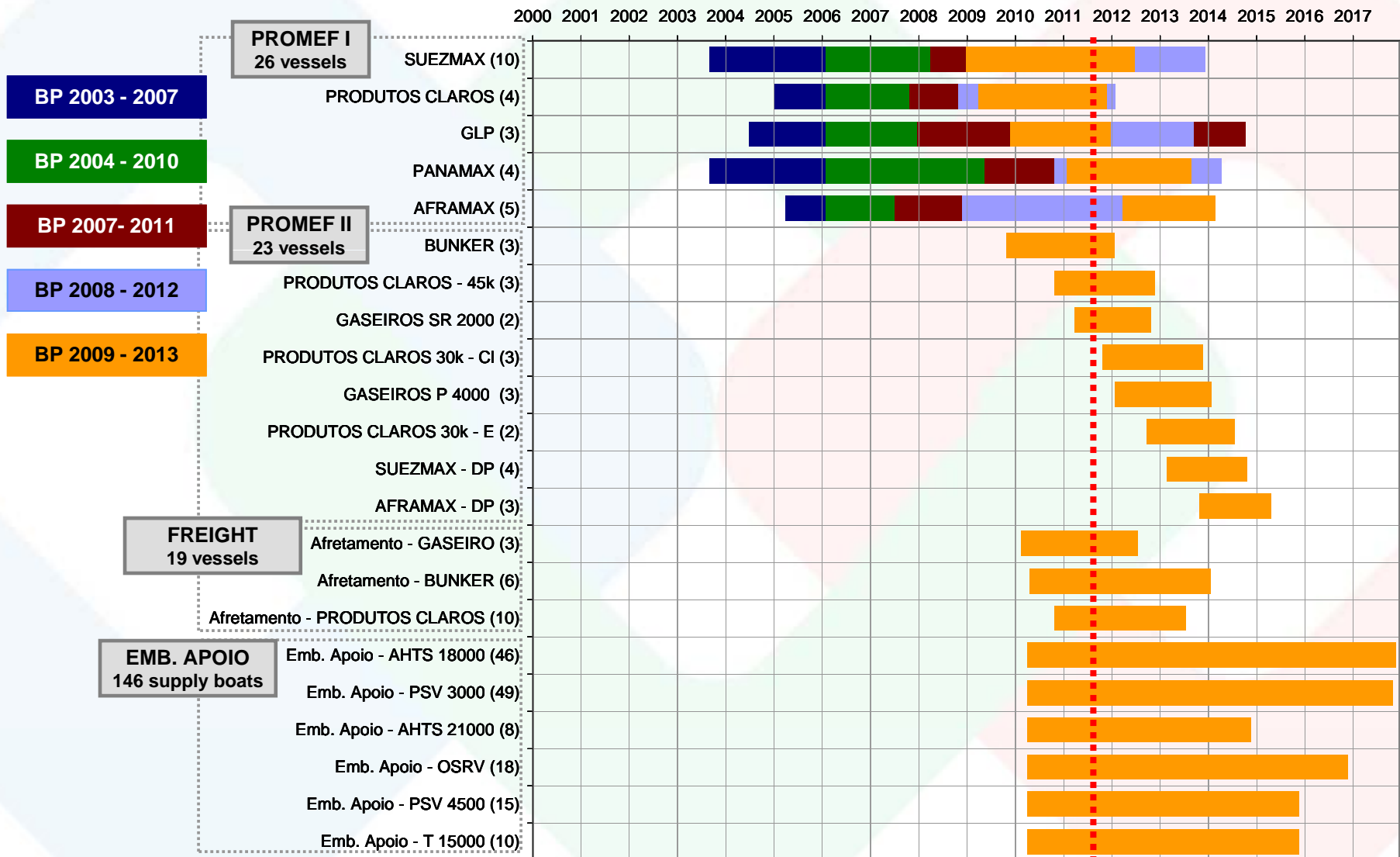

# National Industry Diagnosis Methodology

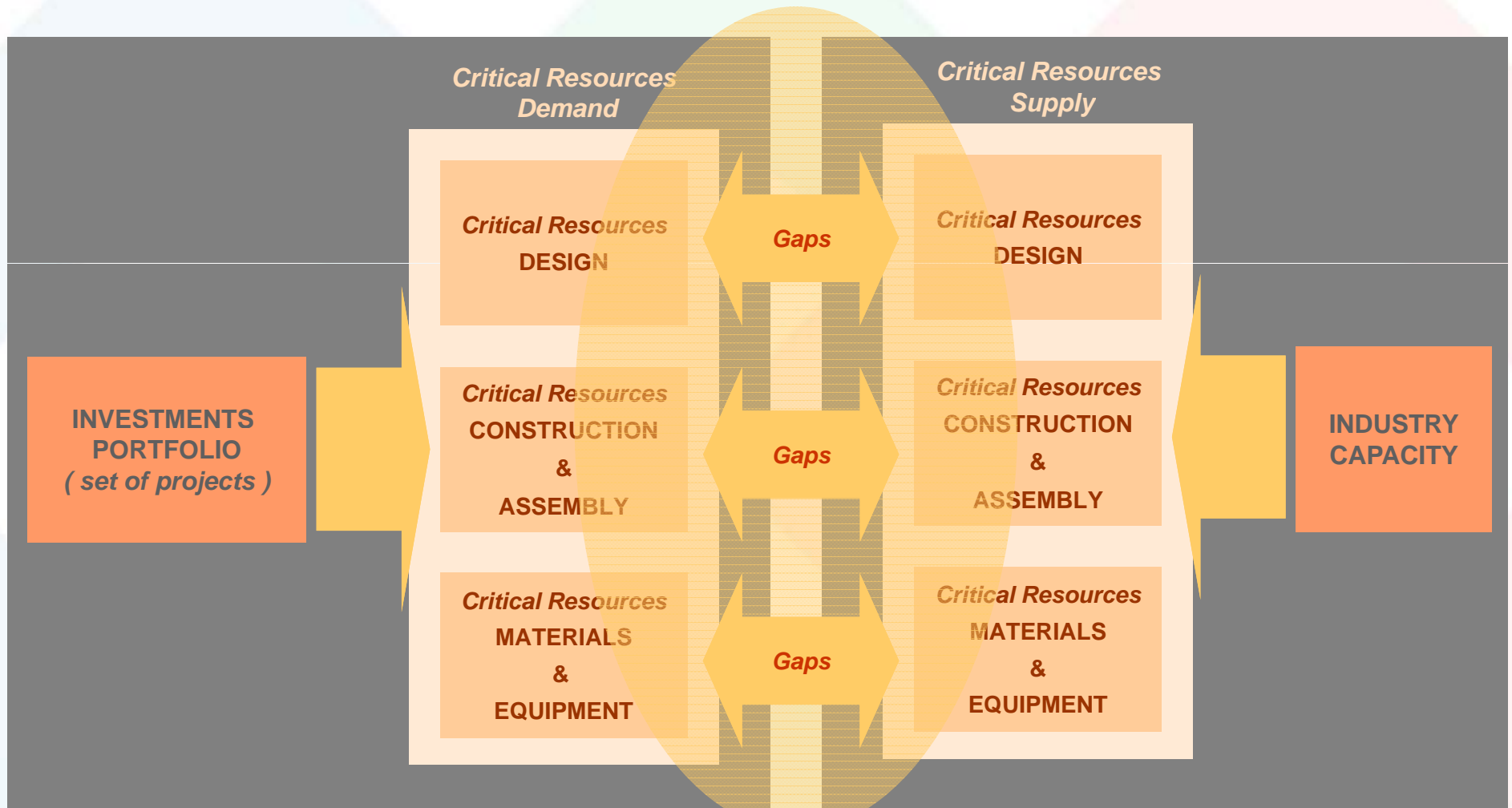

# O&G Demand Driven Industrial Policy

## Concepts and Main Roles



### PIDD - P&G

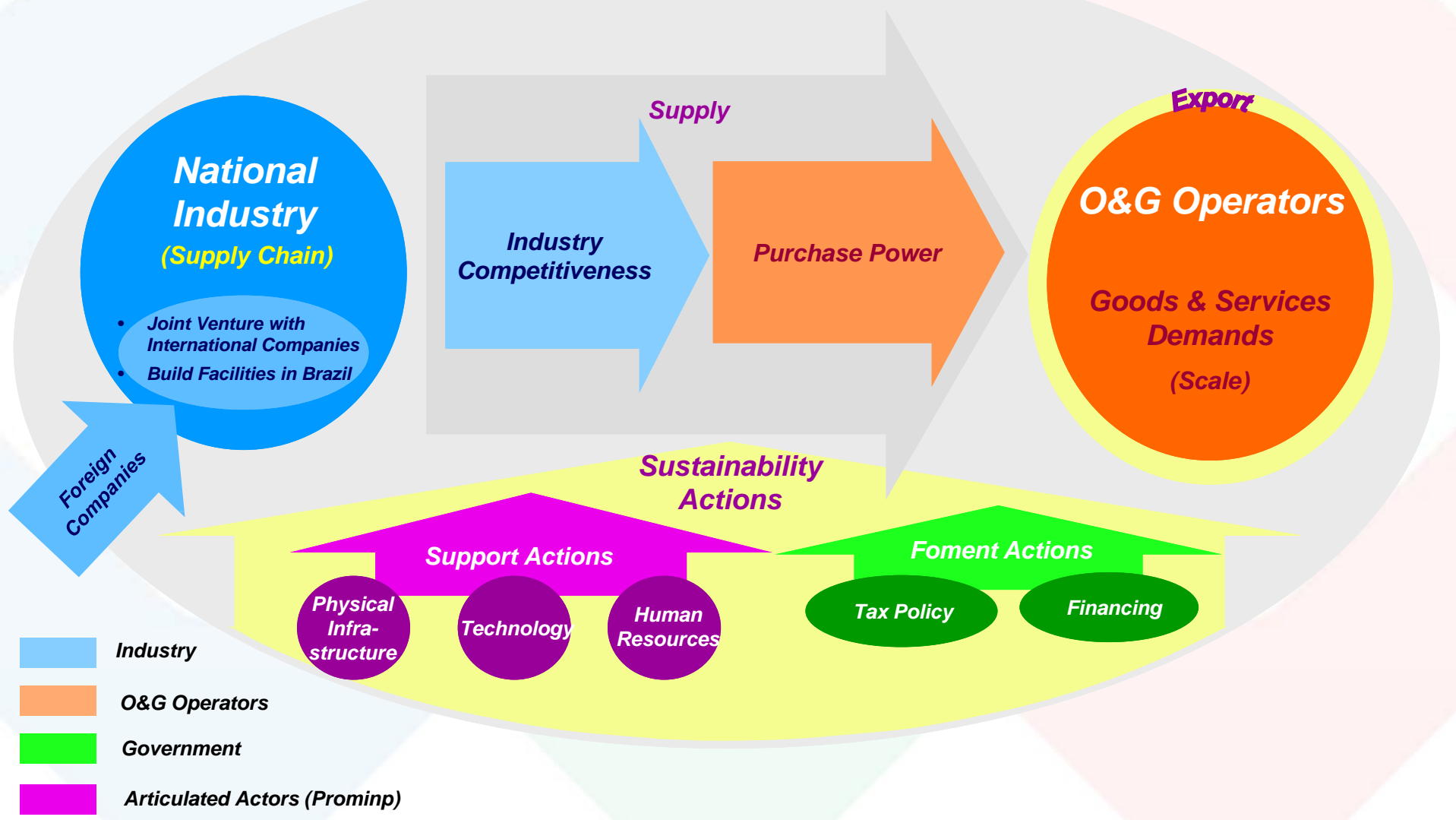

# O&G Demand Driven Industrial Policy

## Concepts and Main Roles



### PIDD - P&G

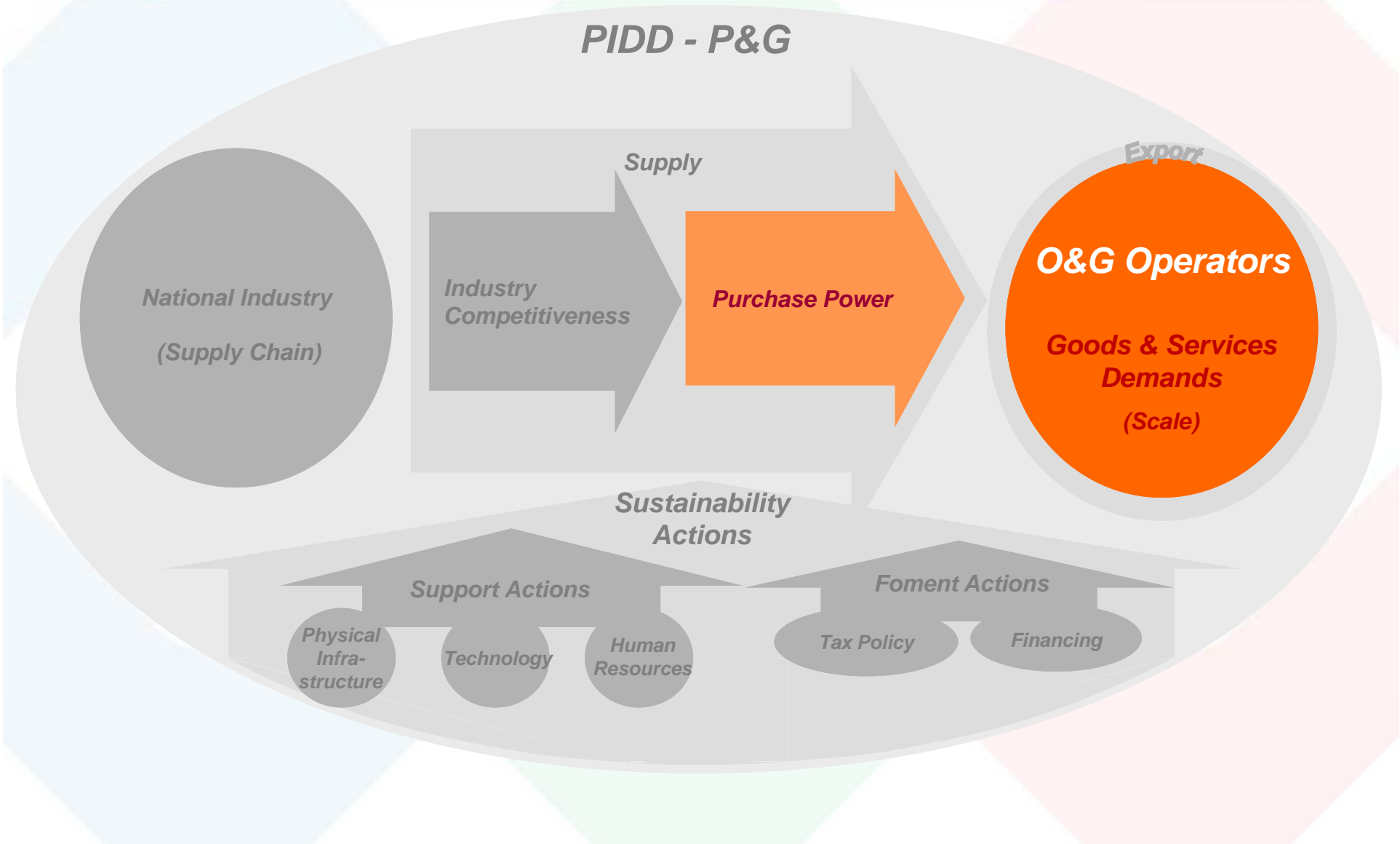

# Supply Chain and Demand Breakdown



## Goods and Services Supply Chain

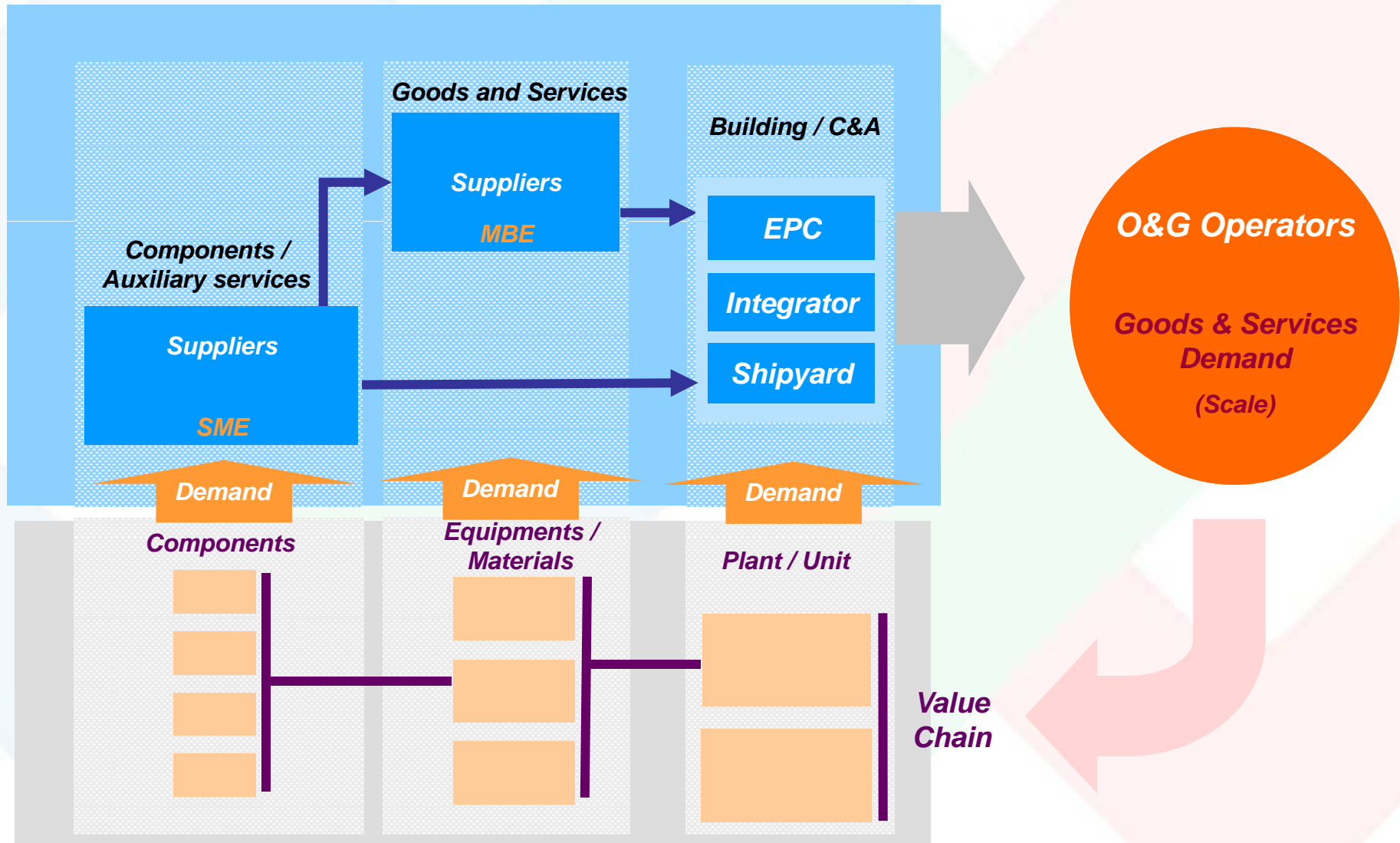

# Equipment Demands

## Business Plan 2010-2014



### Annual Demand by Family

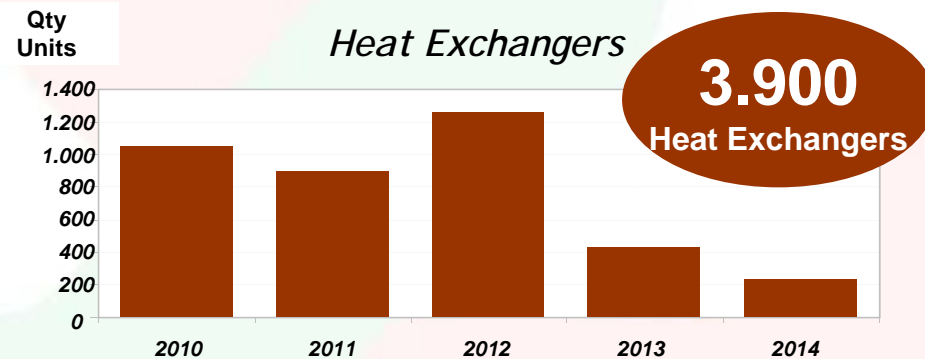
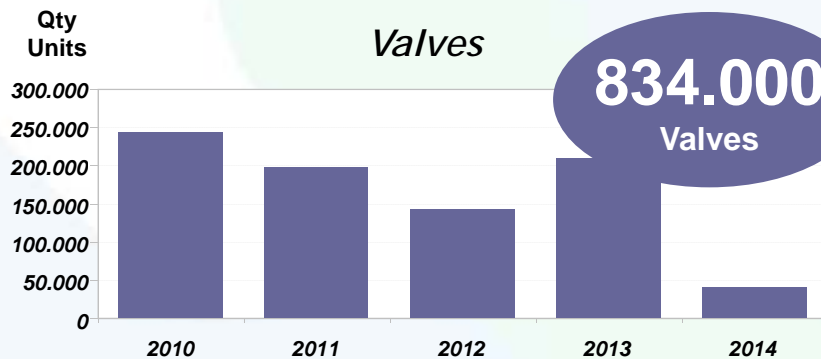
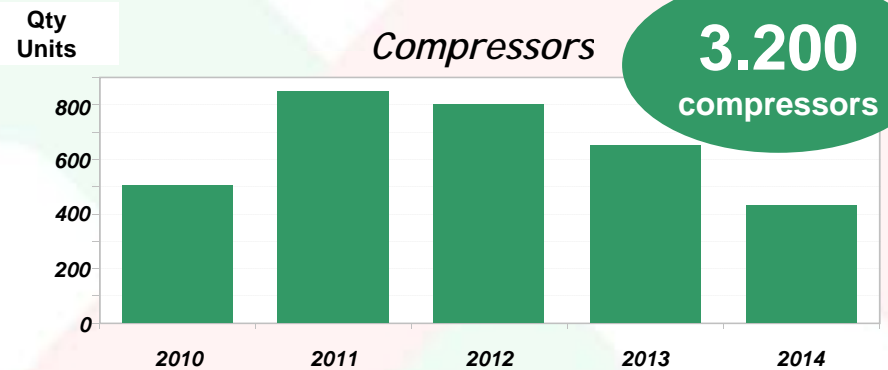
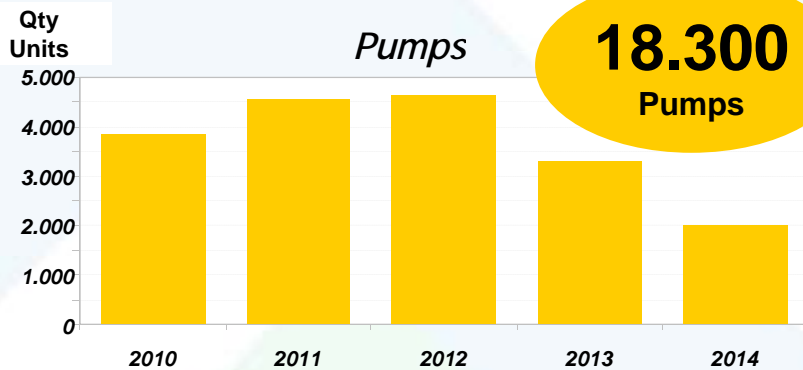

# Equipment Demands

## Business Plan 2010-2014



### Quarterly Demand by Family

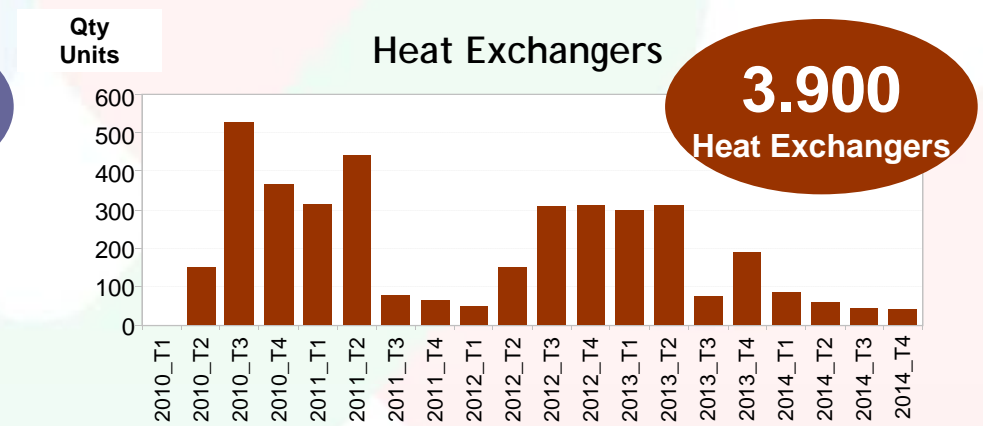
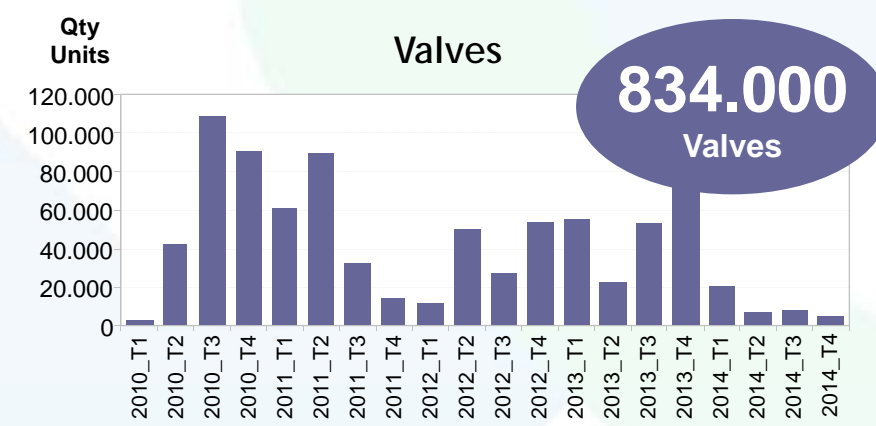
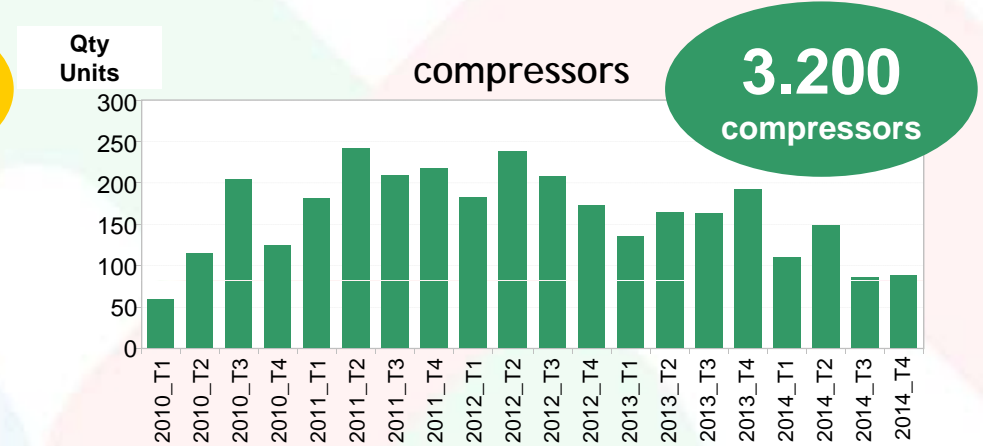
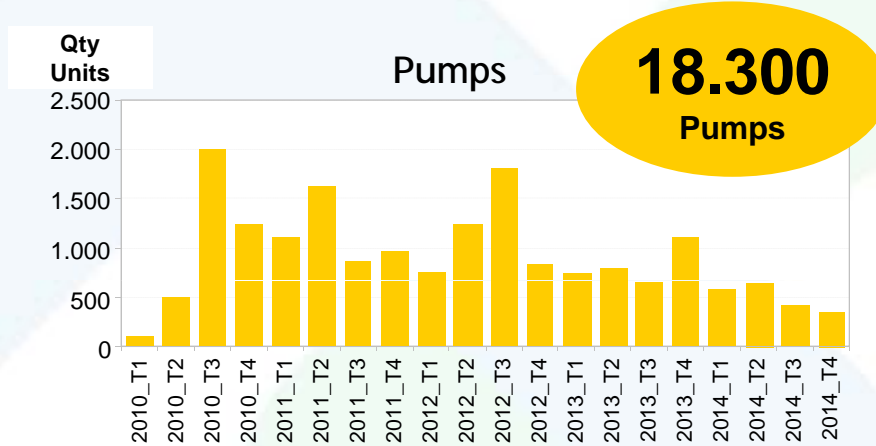

# Equipment Demands

## Business Plan 2010-2014



### Quarterly Demand by Family and SKU

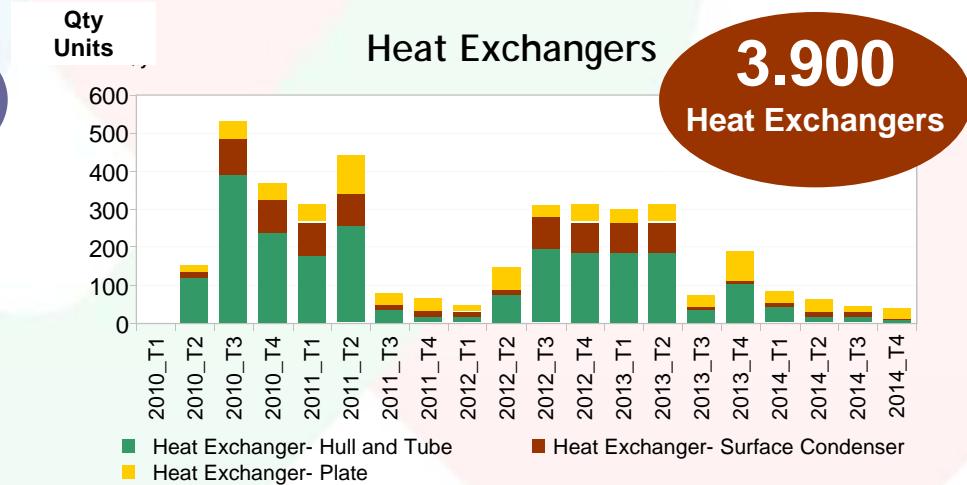
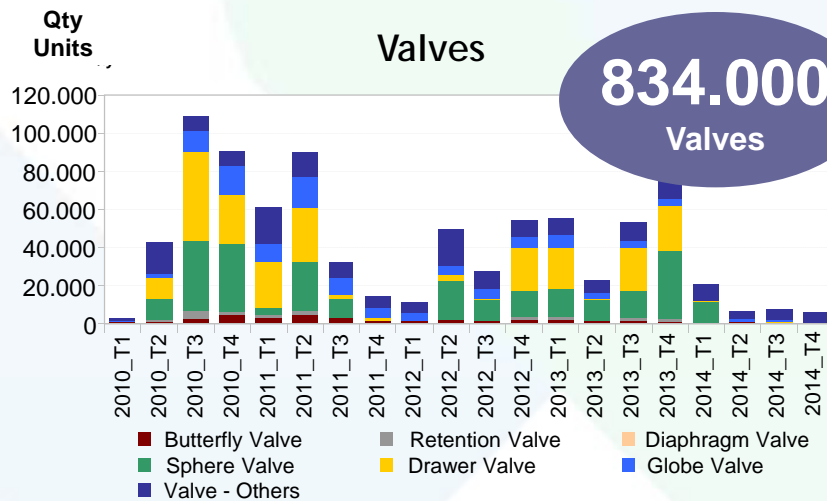
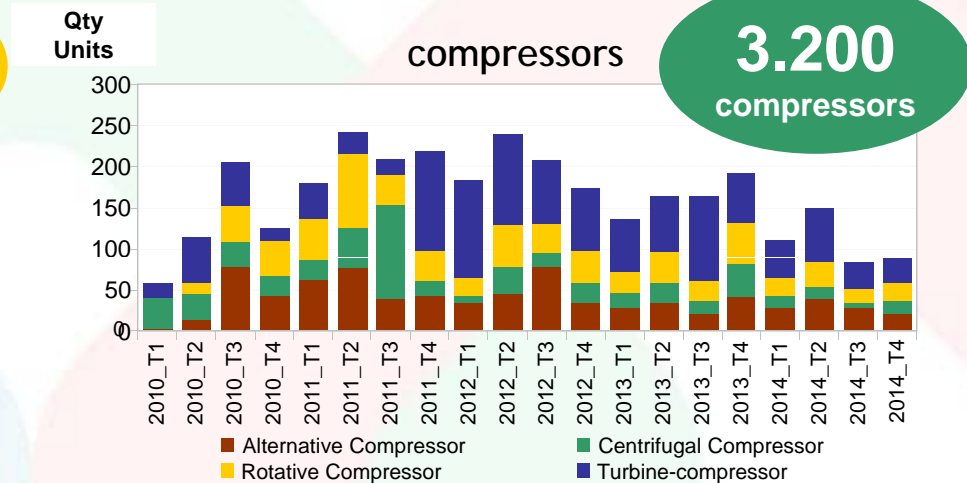
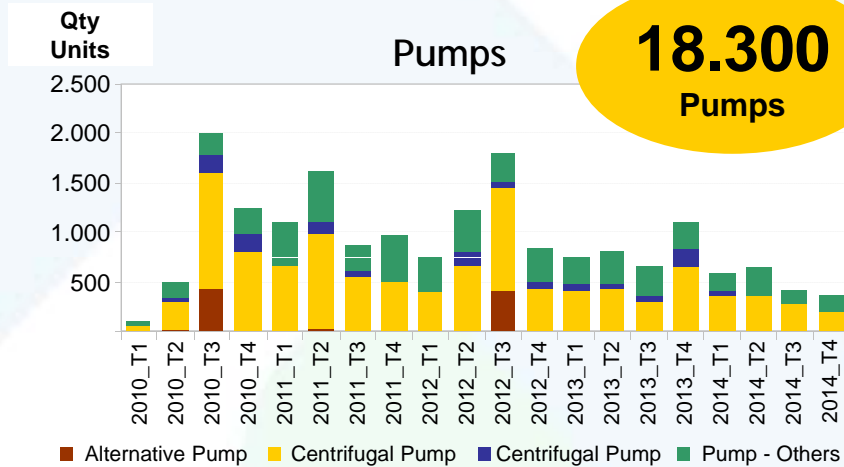

# Equipment Demands

## Business Plan 2010-2014



### Quarterly Demand of equipment

#### Drawer Valve

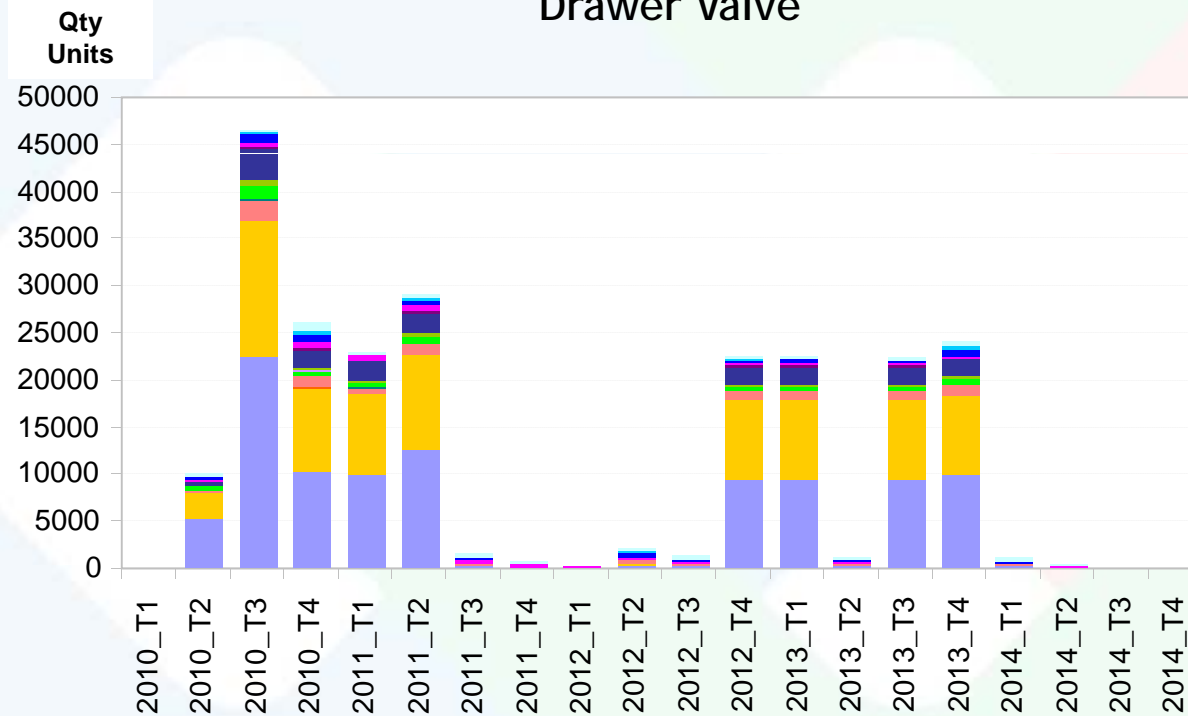

- Válvula Gaveta\_Aço Carbono\_Forjado\_DN Até 1 1/2"
- Válvula Gaveta\_Aço Carbono\_Forjado\_DN = 2" Até 12"
- Válvula Gaveta\_Aço Carbono\_Fundido\_DN Até 12"
- Válvula Gaveta\_Aço Carbono\_Fundido\_DN = 14" até 24"
- Válvula Gaveta\_Aço Carbono\_Fundido\_DN > 24"
- Válvula Gaveta\_Aço Inox\_Forjado\_DN Até 1 1/2"
- Válvula Gaveta\_Aço Inox\_Fundido\_DN Até 1 1/2"
- Válvula Gaveta\_Aço Inox\_Fundido\_DN = 2" Até 12"
- Válvula Gaveta\_Aço Inox\_Fundido\_DN = 14"
- Válvula Gaveta\_Aço Liga\_Forjado\_DN Até 1 1/2"
- Válvula Gaveta\_Aço Liga\_Forjado\_DN = 2" Até 12"
- Válvula Gaveta\_Bronze\_Fundido\_DN Até 1 1/2"
- Válvula Gaveta\_Bronze\_Fundido\_DN = 2" Até 12"
- Válvula Gaveta\_Ferro Fundido\_Fundido\_DN = 2" Até 12"
- Válvula Gaveta\_Ferro Fundido\_Fundido\_DN = 14"
- Válvula Gaveta\_Ni/Br/Al\_Fundido\_DN Até 1 1/2"
- Válvula Gaveta\_Ni/Br/Al\_Fundido\_DN = 2" Até 12"
- Válvula Gaveta\_Indefinido\_Indefinido\_Indefinido
- Válvula Gaveta\_Aço Inox\_Forjado\_DN = 14"

# Components

## Valves Example

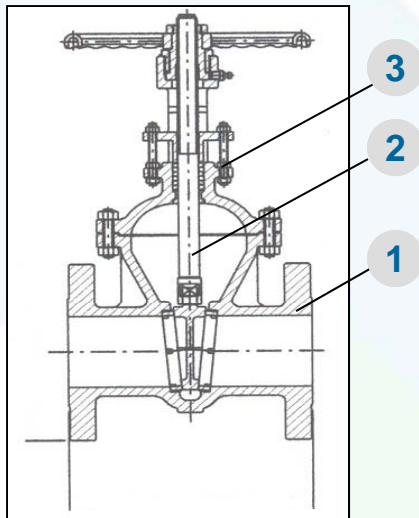

Drawer Valve Example

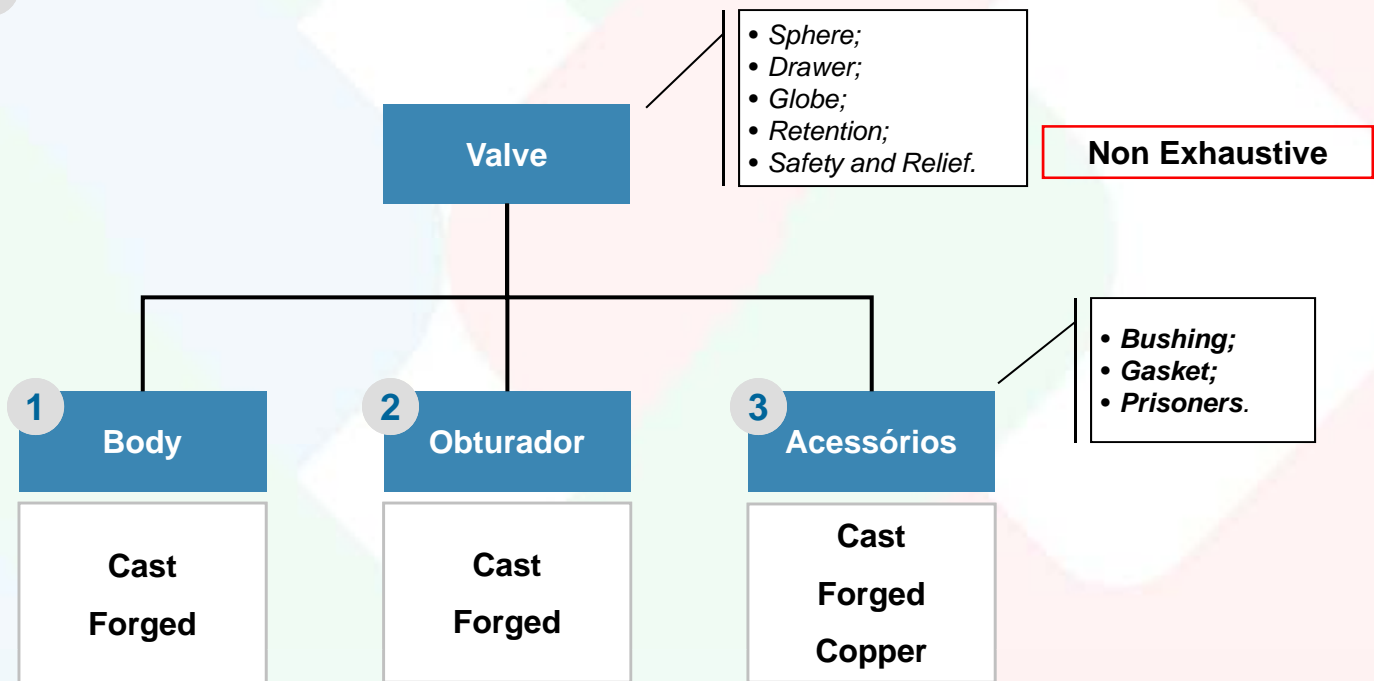

# Component Demands

## Business Plan 2010-2014

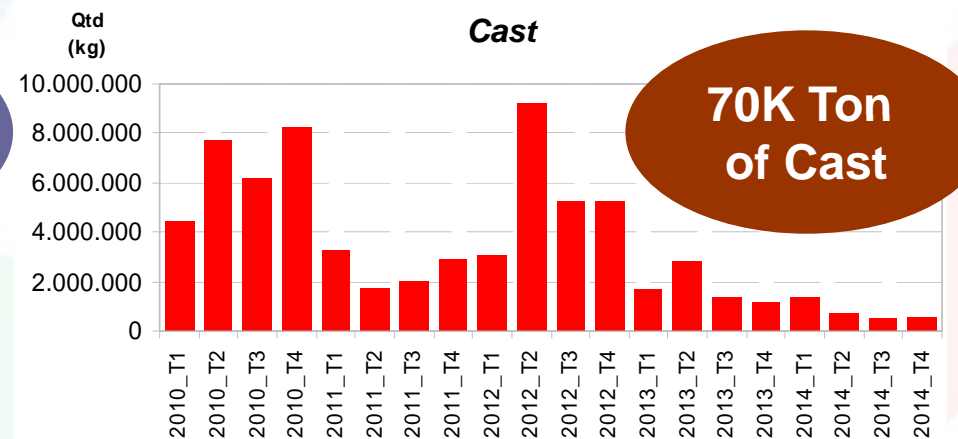
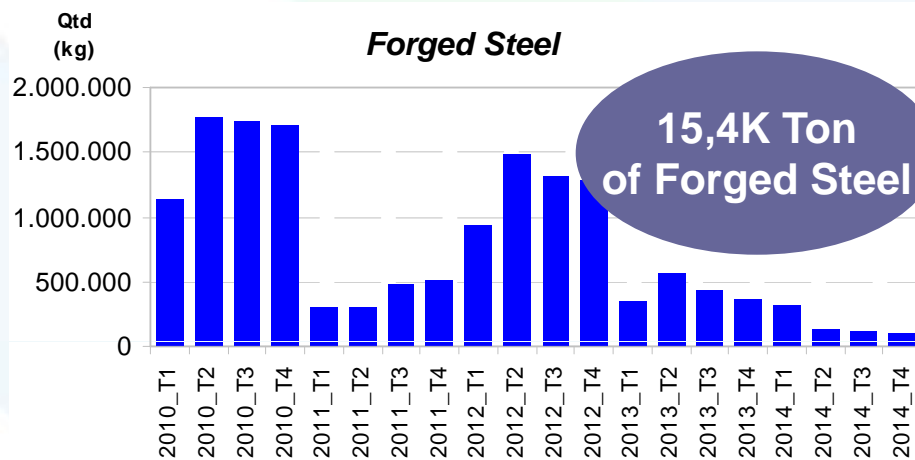
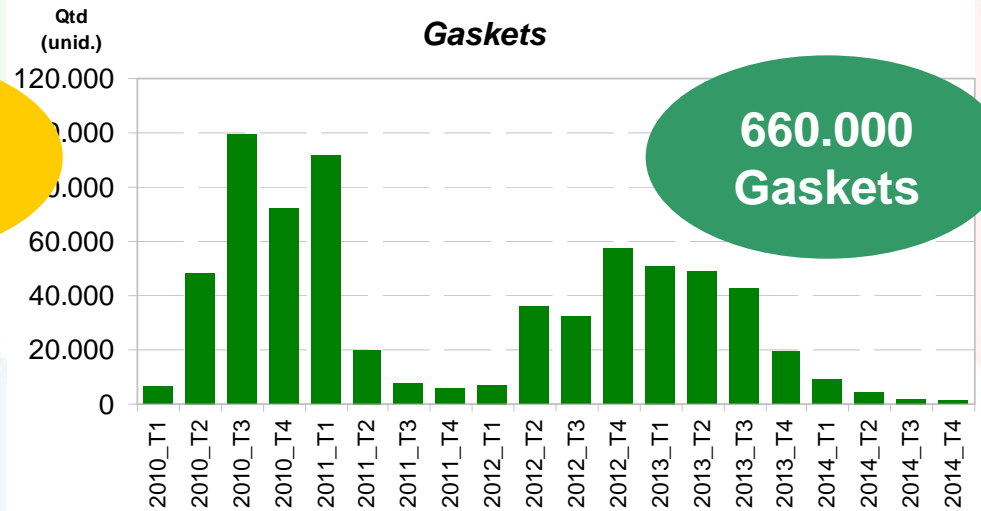
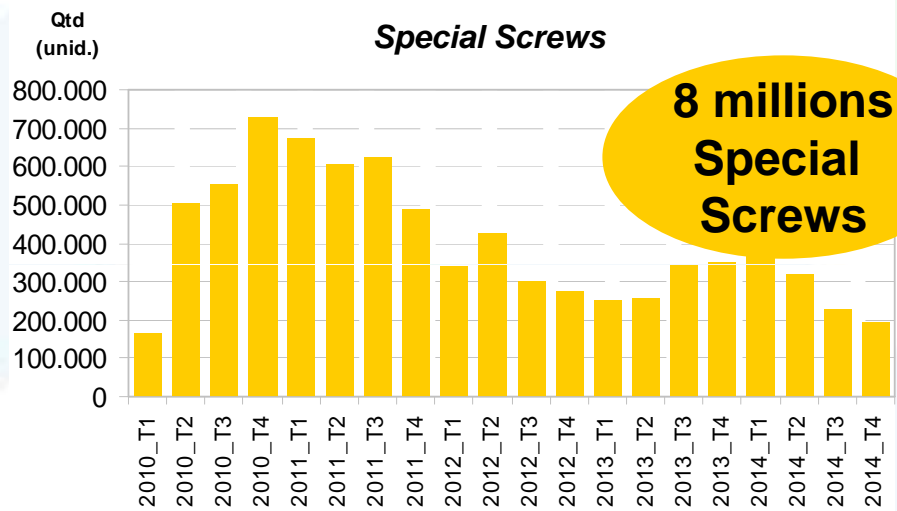

# Portal of Business Opportunities for O&G Supply Chain



v1.0.4

Programa de Mobilização da Indústria  
Nacional de Petróleo e Gás Natural



Portal de Oportunidades da  
Cadeia de Suprimentos do Setor  
de P&G

*Página Inicial*

*Área para Fornecedores*

*Demandas de Materiais e  
Equipamentos*

› *Relatório Consolidado*

*Relatório Detalhado*

*Quem Vende o que eu  
Compro*

*Quem Compra o que eu  
Vendo*

*Prestadores de Serviços*

*Profissionais Qualificados*

*Buscar Produtos*

*Minha Área*

*Sair*



## Veja e seja visto por empresas de todo o Brasil

Aqui você encontra os fornecedores e compradores de bens e serviços do setor de petróleo e gás natural de todo o País, além de informações sobre as demandas de materiais e equipamentos e os investimentos do setor, de uma forma simples e inovadora.

Coloque sua empresa em evidência! Cadastre-a e tenha acesso **gratuito** ao Portal. Conheça a demanda dos seus produtos no setor de P&G, amplie sua visibilidade na cadeia de suprimentos e aumente sua interação com outros fornecedores.

Confira algumas facilidades do Portal:

- **Demanda de materiais e equipamentos:**  
Conheça a demanda nacional dos seus produtos no setor de P&G.
- **Busca por fornecedores e compradores:**  
Visualize quem vende o que você compra e quem compra o que você vende.
- **Maior visibilidade:**  
Veja e seja visto por centenas de empresas da Cadeia de Suprimentos do Setor de P&G.
- **Cadastro fácil e gratuito:**  
Cadastre sua empresa de forma simples e consulte todos os serviços gratuitamente.



[Acesse o tutorial do portal de Oportunidades](#)



Ministério de  
Minas e Energia



# Competitiveness Study of Goods and Services Supplier Industry of Oil and Gas market



## Competitiveness Study

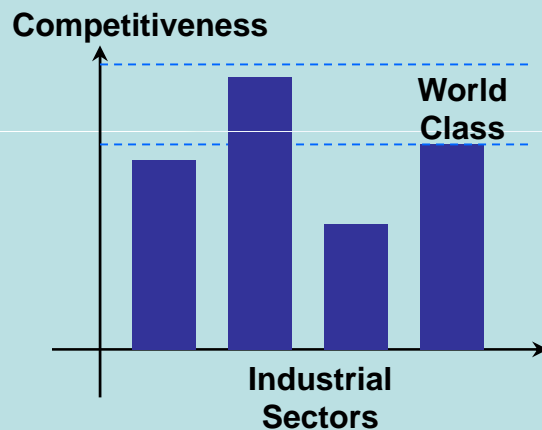

- 18 industrial sub-sectors
- 2 perspectives:
  - Technical-Industrial Qualification
  - Tax and labor legislation, financing and guarantees

Technological Basis		Sectors	
Transformation Industry	Metallurgical Technology	Mills	
		Pipelines	
		Flanges and Connections	
		Boiler Works	
	Mechanical Technology	Rods and Socker Road Pumps	
		Subsea	
		Naval Parts	Pumps
			Compressors
			Diesel / Gas Motors
			Turbines
Cranes and Hoists			
Electrical Technology	Valves		
	Generators and Electrical Motors		
	Transformers and Substatiois		
Services	Instrumentation and Automation		
	Engineering		
		Construction and Assembly	

# National Industry Competitiveness Diagnosis

## General Competitiveness Roadmap



Technological Basis		Sectors	Gaps / Challenges									
			Infra-Structure			Technology					Human Resources	
			Insufficient production capacity for future demand	Incomplete Product Portfolio	Low Local Content	Low R&D Activity	Process Technology	Basic Industrial Technology	Engineering	Professional Qualification		
Transformation Industry	Metallurgical Technology	Steel Mills										
		Pipelines										
		Flanges and Connections										
		Boiler Works										
	Mechanical Technology	Ship Parts	Rods and Sucker Rod Pumps									
			Subsea									
		Pumps										
		Compressors										
		Gas / Diesel Engines										
		Turbines										
		Cranes and Hoists										
		Valves and City Gates										
		Electrical Technology	Generators and Electric Engines									
			Substations and Transformers									
	Automation and Instrumentation											
Services	Engineering											
	Construction and Assembly											

# National Industry Competitiveness Diagnosis

## High Level Competitiveness Sectors



Technological Basis	Sectors	Gaps / Challenges									
		Infra-Structure			Technology					Human Resources	
		Capacity gaps for future the demand growth	Incomplete Product Portfolio	Low Local Content	Low R&D Activity	Process Technology	Basic Industrial Technology	Engineering	Professional Qualification		
Transformation Industry	Metallurgical Technology	Steel Mills									
		Pipelines									
		Flanges and Connections									
		Boiler Works									
	Mechanical Technology	Rods and Sucker Rod Pumps									
			Subsea								
		Ship Parts	Pumps								
			Compressors								
			Gas / Diesel Engines								
			Turbines								
			Cranes and Hoists								
			Valves and City Gates								
	Electrical Technology	Generators and Electric Engines									
		Substations and Transformers									
		Automation and Instrumentation									
Services	Engineering										
	Construction and Assembly										

# National Industry Competitiveness Diagnosis

## Medium Level Competitiveness Sectors



Technological Basis	Sectors	Gaps / Challenges										
		Infra-Structure			Technology					Human Resources		
		Capacity gaps for future the demand growth	Incomplete Product Portfolio	Low Local Content	Low R&D Activity	Process Technology	Basic Industrial Technology	Engineering	Professional Qualification			
Transformation Industry	Metallurgical Technology	Steel Mills										
		Pipelines										
		Flanges and Connections										
		Boiler Works										
	Mechanical Technology	Rods and Sucker Rod Pumps										
			Subsea									
		Naval Parts	Pumps									
			Compressors									
			Gas / Diesel Engines									
			Turbines									
			Cranes and Hoists									
		Valves and City Gates										
		Electrical Technology	Generators and Electric Engines									
	Substations and Transformers											
	Automation and Instrumentation											
Services	Engineering											
	Construction and Assembly											

# National Industry Competitiveness Diagnosis

## Sectors With No Significant National Production



Technological Basis	Sectors	Gaps / Challenges										
		Infra-Structure			Technology					Human Resources		
		Capacity gaps for future the demand growth	Incomplete Product Portfolio	Low Local Content	Low R&D Activity	Process Technology	Basic Industrial Technology	Engineering	Professional Qualification			
Transformation Industry	Metallurgical Technology	Steel Mills										
		Pipelines										
		Flanges and Connections										
		Boiler Works										
	Mechanical Technology	Rods and Sucker Rod Pumps										
			Subsea									
		Naval Parts	Pumps									
			<b>Compressors</b>									
			<b>Gas / Diesel Engines</b>									
			<b>Turbines</b>									
	Electrical Technology	Cranes and Hoists										
		Valves and City Gates										
		Generators and Electric Engines										
		Substations and Transformers										
Services	Engineering											
	Construction and Assembly											

# O&G Demand Driven Industrial Policy

## Concepts and Main Roles



### PIDD - P&G

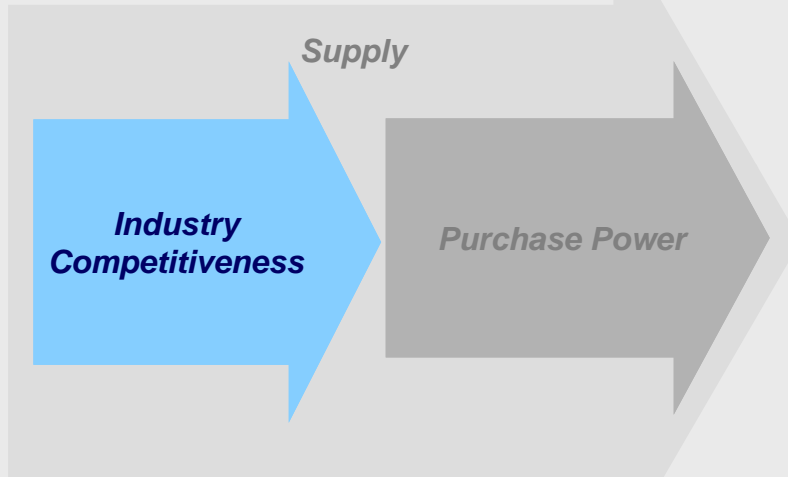

### Sustainability Actions

#### Support Actions



#### Foment Actions



# National Industry Competitiveness Diagnosis

## Industry's Knowledge Sources



Technological Basis		Sectors	Internal Sources				External Sources					
			Domestic R&D	Engineering	Learning by doing	Matrix	Intra-industrial		Infra-structure			
							Client	Suppliers	Universities and Research Centers	Normalization	Technology Transfer	
Transformation Industry	Metallurgical Technology	Mills	■	■			■	■				
		Pipelines	■	■			■	■				
		Flanges and Connections			■					■		
		Boiler Works									■	
	Mechanical Technology	Rods and Socker Road Pumps	Rods and Socker Road Pumps			■		■	■			
			Subsea	■					■	■		
		Naval Parts	Pumps					■	■			
			Compressors					■	■			
			Diesel / Gas Motors					■	■			
			Turbines					■	■			
			Crains and Hoists					■	■			
	Valves								■			
	Electrical Technology	Generators and Electrical Motors	■									
		Transformers and Substations										
Instrumentation and Automation					■							
Services	Engineering		■					■		■		
	Construction and Assembly		■					■				

Low R&D Investment

Strong Cooperation with O&G Operators

Industry and University Gap



Used knowledge sources



Not Used knowledge sources

# National Industry Competitiveness Diagnosis

## *Industry and R&D Institutions Interaction*

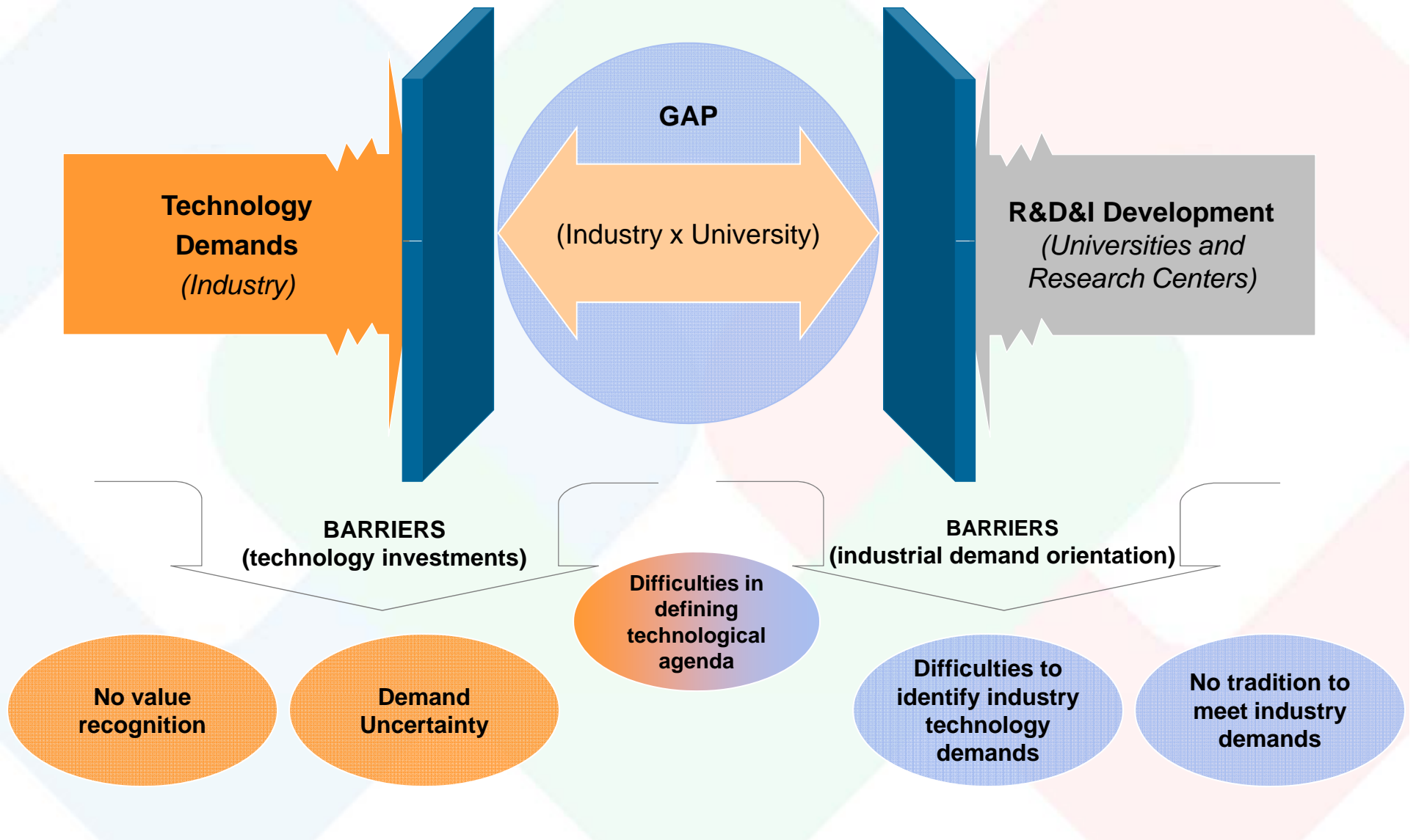

*Technological Development of Supplier Industry  
of Goods and Services*  
*Bottlenecks of Current Model*

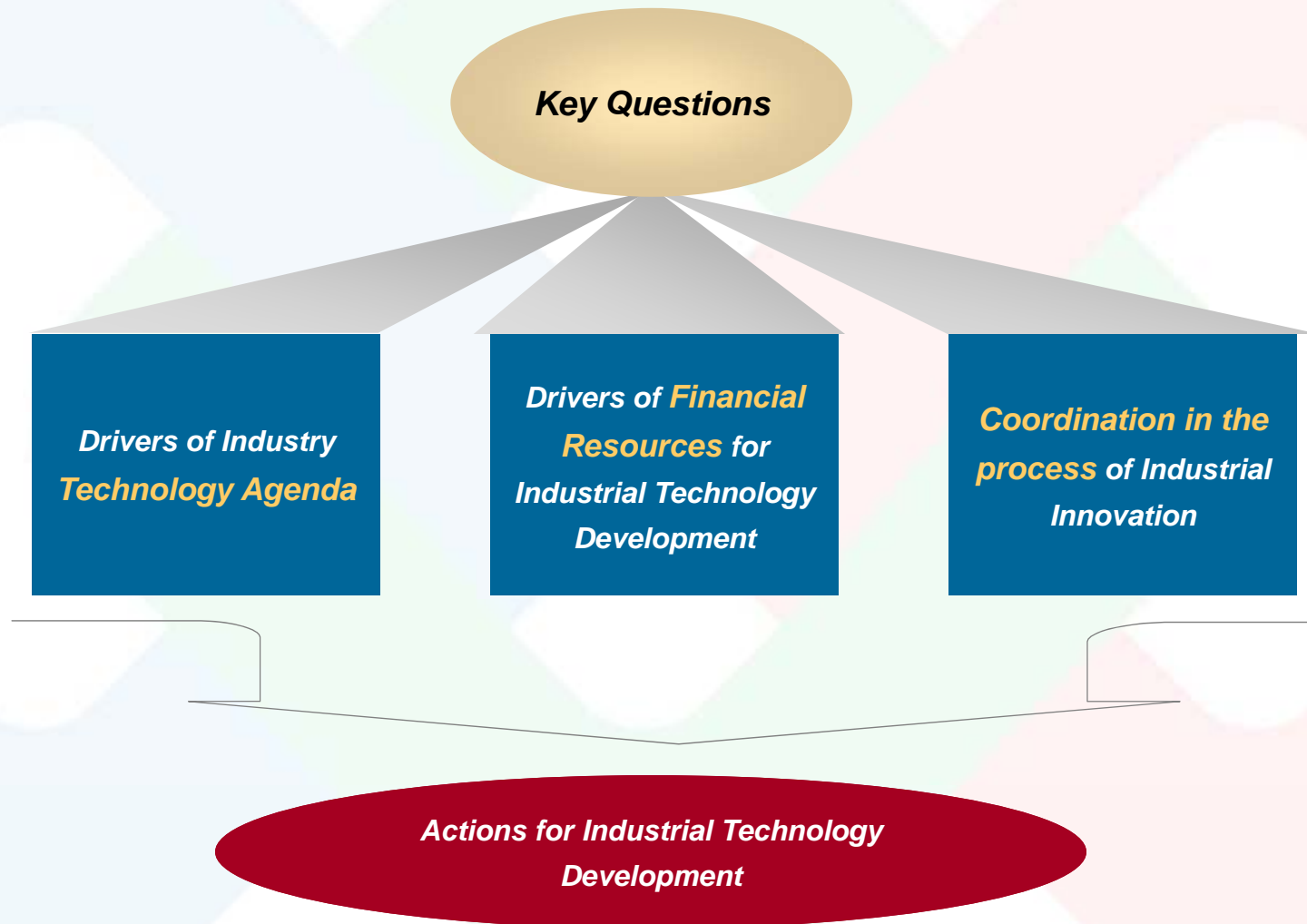



# Industrial Technology Development Plan

## Achieved Results



18 Sectors Analyzed

Competitiveness diagnosis

Technology Gaps

Routes

Base Tecnológica		Setor	
Indústria de Transformação	Tecnologia Metalúrgica	Siderurgia	
		Tubos	
		Conexões e Flanges	
		Caldeiraria	
	Tecnologia Mecânica	Hastes e Unidades de Bombeio	Subsea
			Bombas
		Navieças	Compressores
			Motores a Gás e Diesel
			Turbinas
			Guindastes e Guinchos
			Válvulas Industriais
			Geradores e Motores Elétricos
		Tecnologia Elétrica	Subestação e Transformadores
			Instrumentação
	Serviços	Serviços de Engenharia	
		Construção e Montagem	

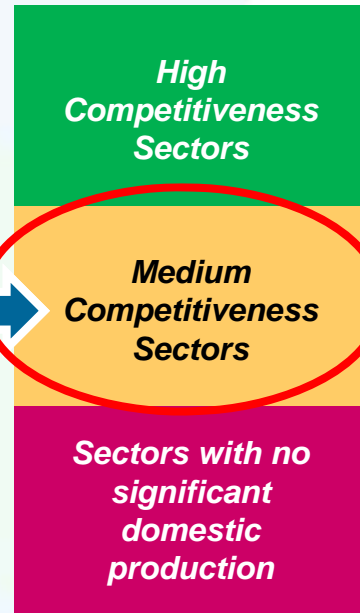

Válvulas	7
Conexões e Flanges	5
Caldeiraria	5
Umbilicais	6
Construção Naval	7
Instrument. e Automação	8

Technology Projects



# O&G Demand Driven Industrial Policy

## Concepts and Main Roles



### PIDD - P&G

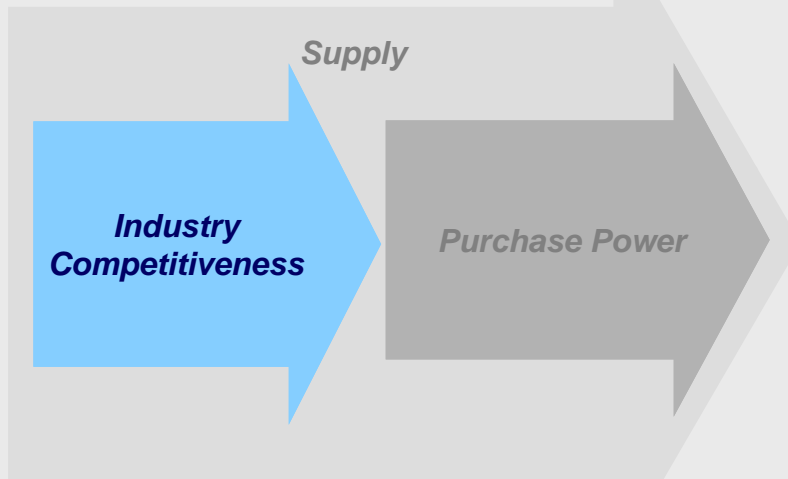

### Sustainability Actions

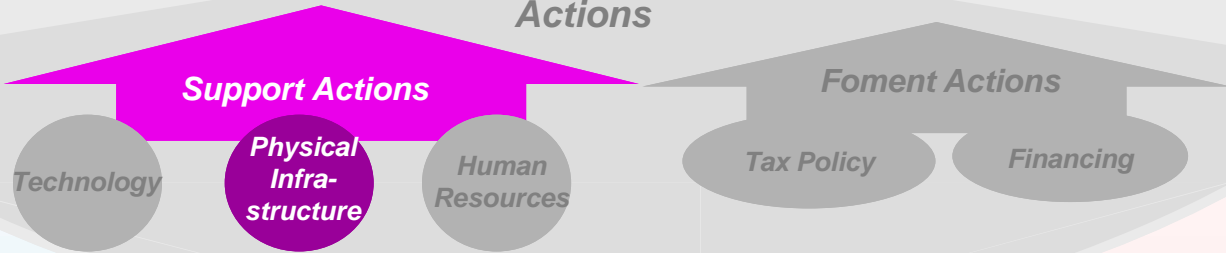

# National Competitive Supply of Goods & Services

## *Adequacy of National Supplier Estate*



### GOODS AND SERVICES SUPPLY

### ACTION ROUTES

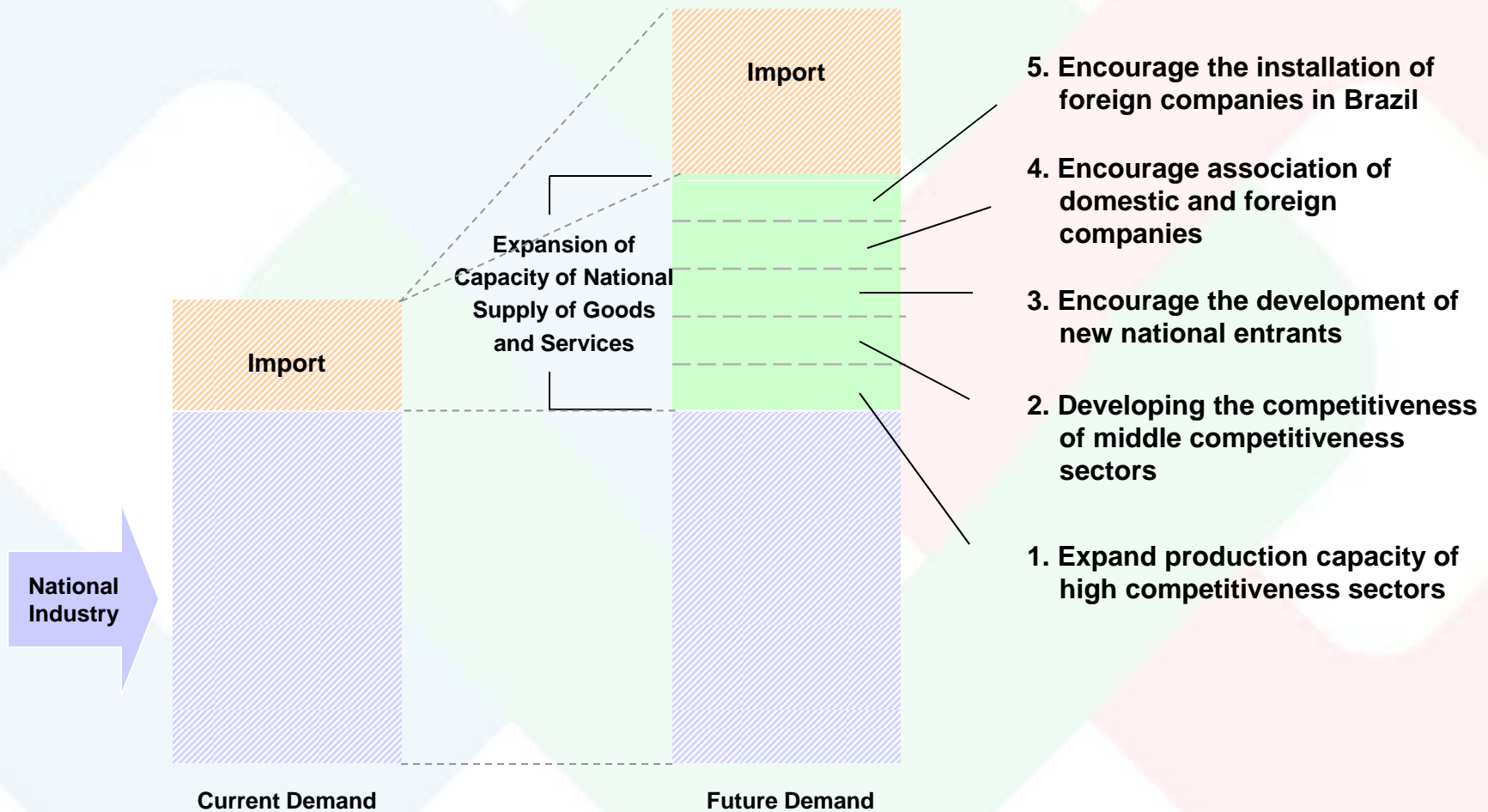

# Industrial Sectors Performance Analysis

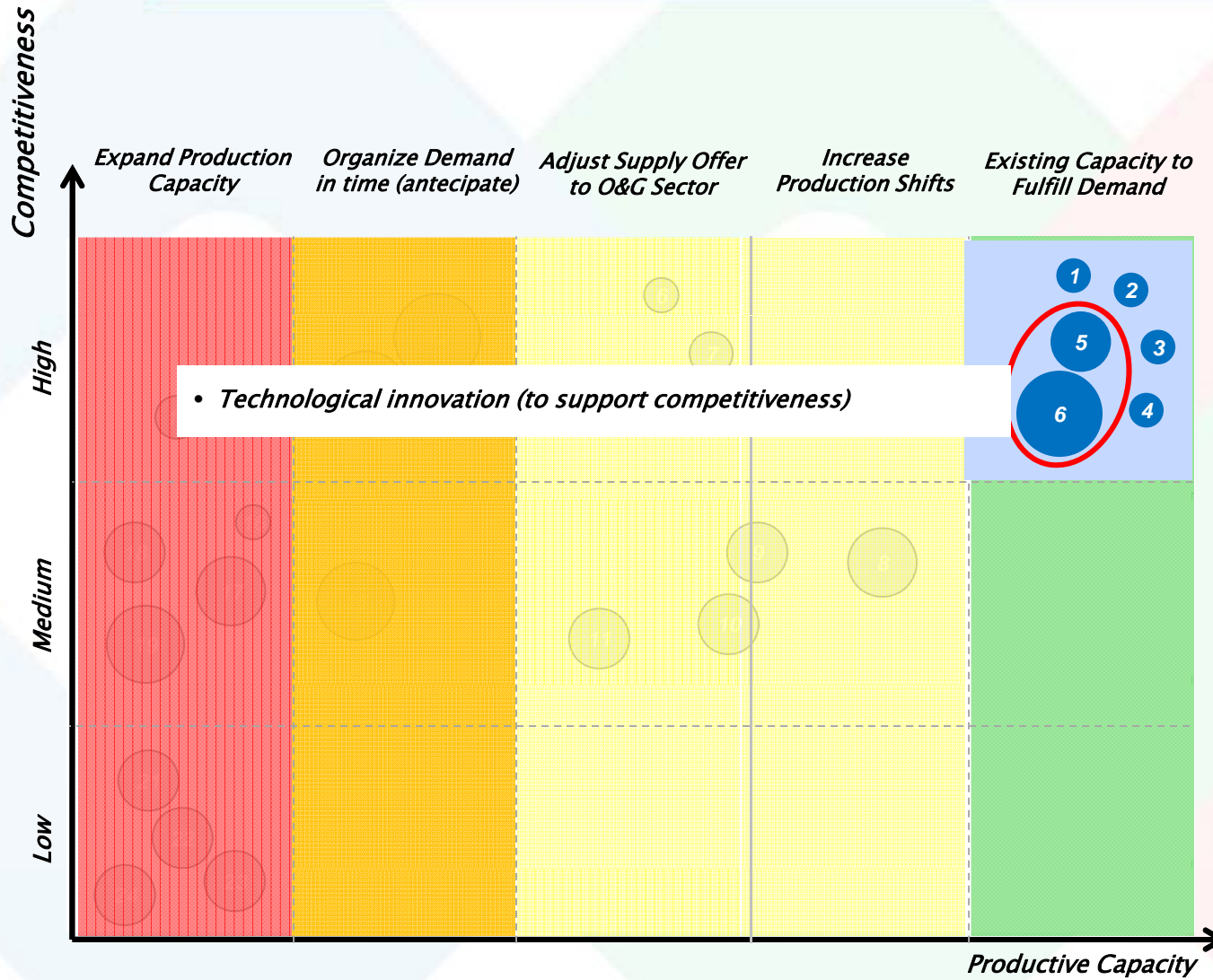

## Sectors

1. Telecommunication
2. Substation and transformers
3. Generators and Motors
4. Electrical Distribution Panels
5. Automation
6. Pipelines
7. Winches
8. Valves
9. Flanges and Connections
10. Boilers Works
11. Mills
12. Steam Turbines
13. Subsea – Equipment
14. Subsea – Umbilical and Flexible Pipes
15. Pumps
16. Alternative Compressors
17. Engines
18. Cranes (Onshore)
19. Engineering Services
20. Construction and Assembly
21. Instrumentation and Measurement
22. Gas Turbines
23. Centrifugal Compressors
24. Electrical Motors (large size)

## Legend

- Degree of dependence of O&G
- Low
  - Medium
  - High

# Industrial Sectors Performance Analysis

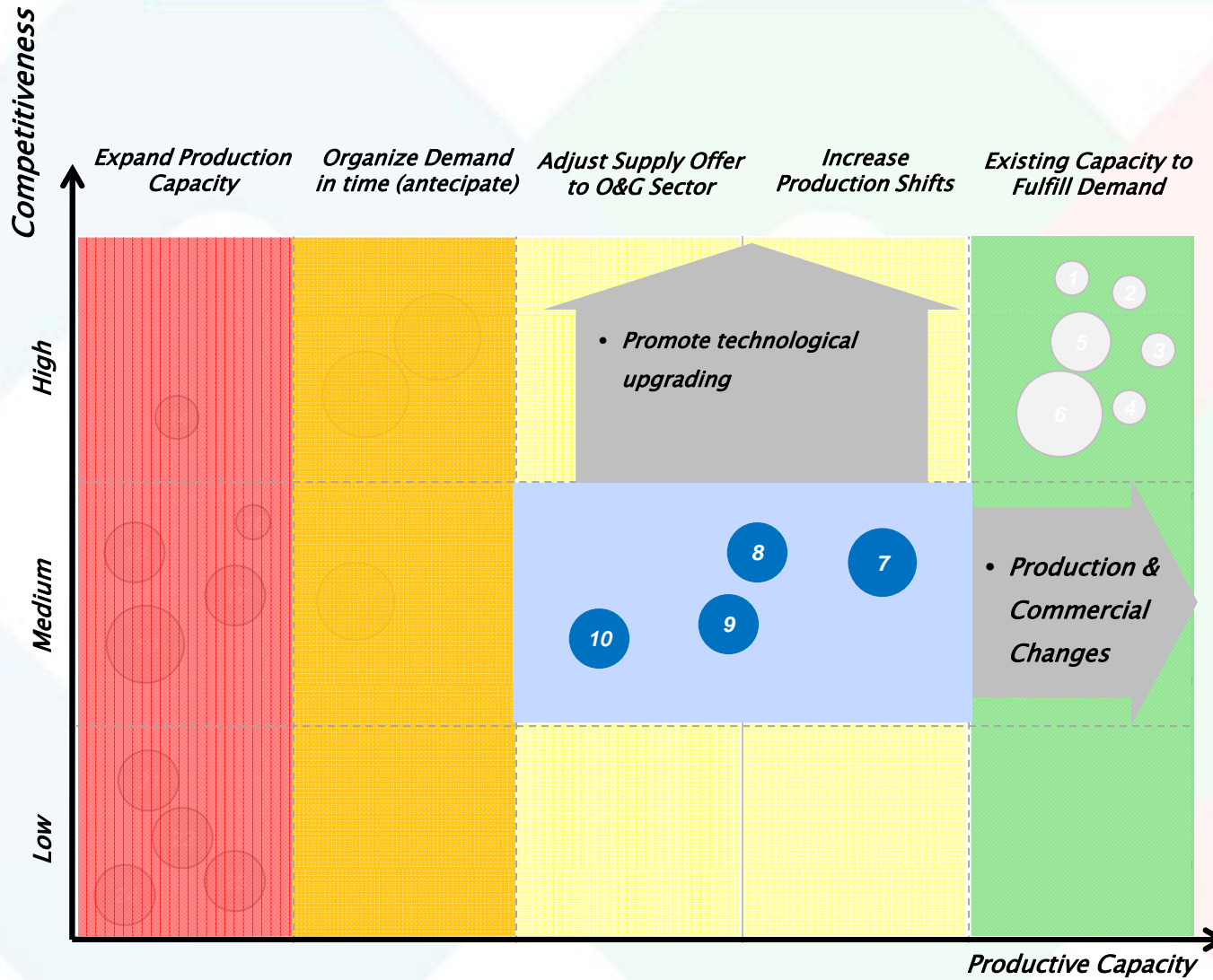

## Sectors

1. Telecommunication
2. Substation and transformers
3. Generators and Motors
4. Electrical Distribution Panels
5. Automation
6. Pipelines
7. Winches
8. Valves
9. Flanges and Connections
10. Boilers Works
11. Mills
12. Steam Turbines
13. Subsea – Equipment
14. Subsea – Umbilical and Flexible Pipes
15. Pumps
16. Alternative Compressors
17. Engines
18. Cranes (Onshore)
19. Engineering Services
20. Construction and Assembly
21. Instrumentation and Measurement
22. Gas Turbines
23. Centrifugal Compressors
24. Electrical Motors (large size)

## Legend

- Degree of dependence of O&G
- Low
  - Medium
  - High

# Industrial Sectors Performance Analysis

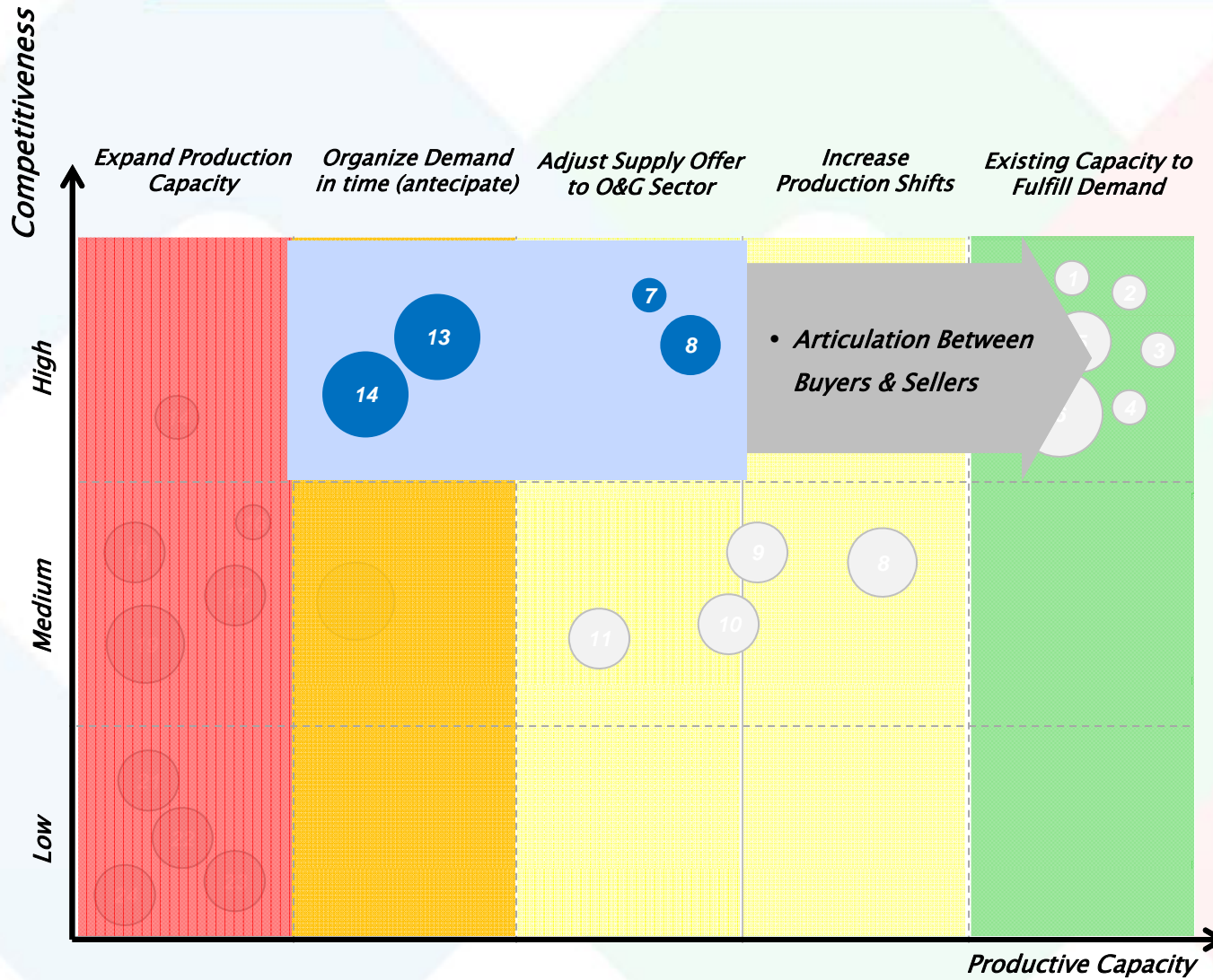

## Sectors

1. Telecommunication
2. Substation and transformers
3. Generators and Motors
4. Electrical Distribution Panels
5. Automation
6. Pipelines
7. Winches
8. Valves
9. Flanges and Connections
10. Boilers Works
11. Mills
12. Steam Turbines
13. Subsea – Equipment
14. Subsea – Umbilical and Flexible Pipes
15. Pumps
16. Alternative Compressors
17. Engines
18. Cranes (Onshore)
19. Engineering Services
20. Construction and Assembly
21. Instrumentation and Measurement
22. Gas Turbines
23. Centrifugal Compressors
24. Electrical Motors (large size)

## Legend

- Degree of dependence of O&G
- Low
  - Medium
  - High

# Industrial Sectors Performance Analysis

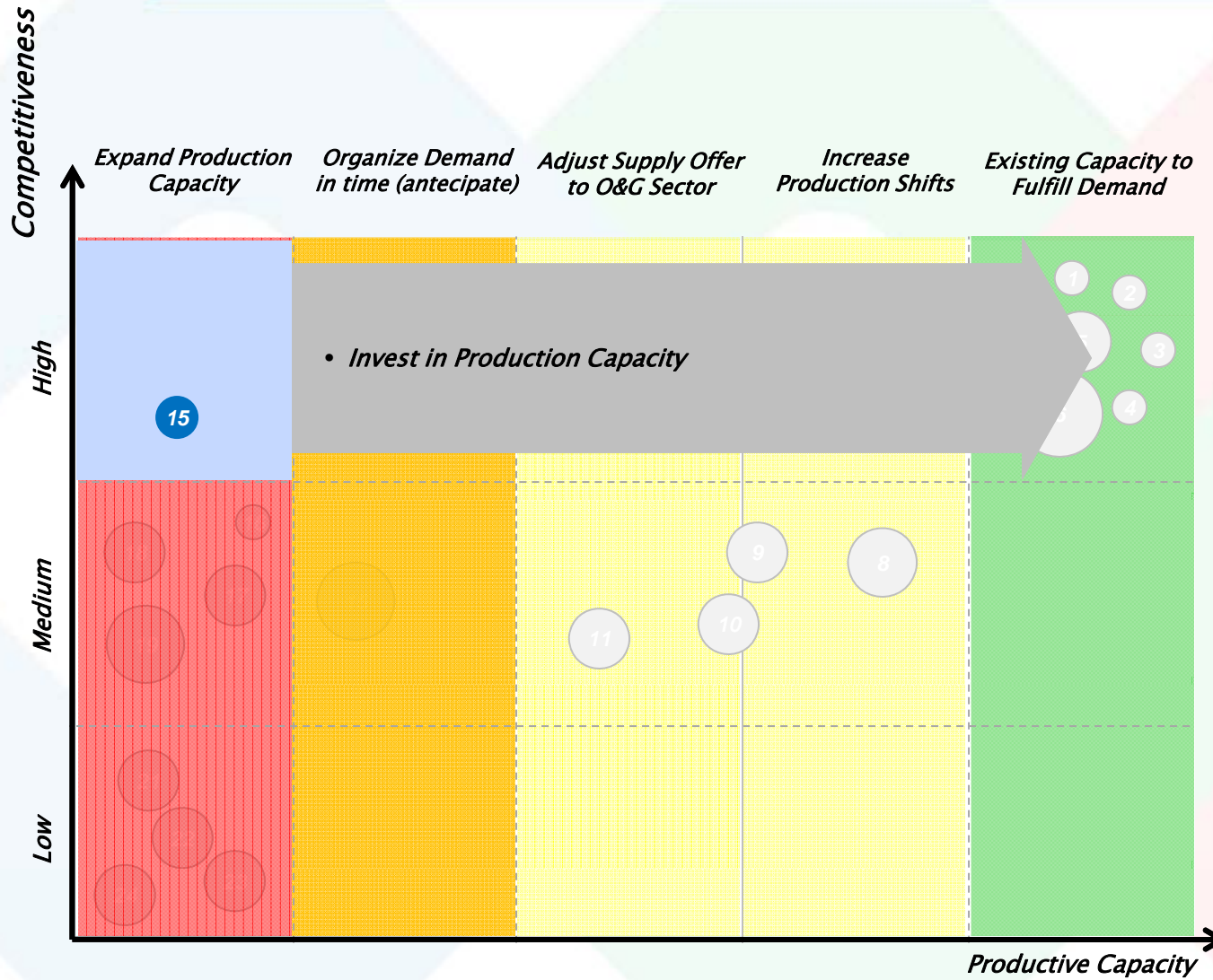

## Sectors

1. Telecommunication
2. Substation and transformers
3. Generators and Motors
4. Electrical Distribution Panels
5. Automation
6. Pipelines
7. Winches
8. Valves
9. Flanges and Connections
10. Boilers Works
11. Mills
12. Steam Turbines
13. Subsea – Equipment
14. Subsea – Umbilical and Flexible Pipes
15. Pumps
16. Alternative Compressors
17. Engines
18. Cranes (Onshore)
19. Engineering Services
20. Construction and Assembly
21. Instrumentation and Measurement
22. Gas Turbines
23. Centrifugal Compressors
24. Electrical Motors (large size)

## Legend

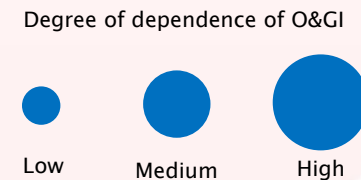

# Industrial Sectors Performance Analysis

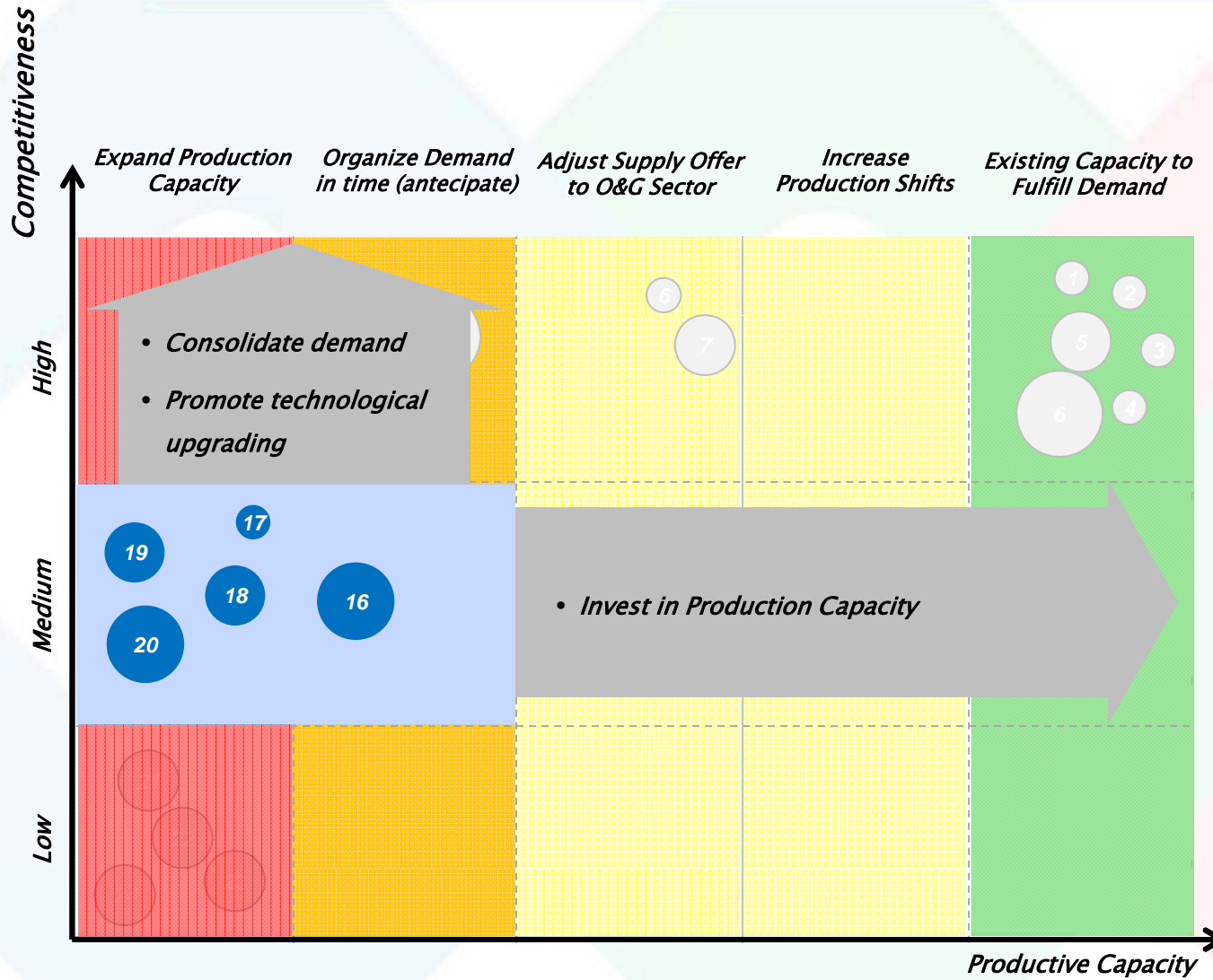

## Sectors

1. Telecommunication
2. Substation and transformers
3. Generators and Motors
4. Electrical Distribution Panels
5. Automation
6. Pipelines
7. Mills
8. Steam Turbines
9. Winches
10. Valves
11. Flanges and Connections
12. Boilers Works
13. Subsea – Equipment
14. Subsea – Umbilical and Flexible Pipes
15. Pumps
16. Alternative Compressors
17. Engines
18. Cranes (Onshore)
19. Engineering Services
20. Construction and Assembly
21. Instrumentation and Measurement
22. Gas Turbines
23. Centrifugal Compressors
24. Electrical Motors (large size)

## Legend

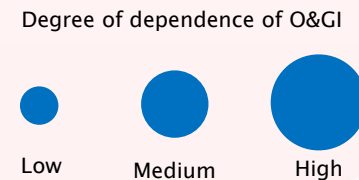

# Industrial Sectors Performance Analysis

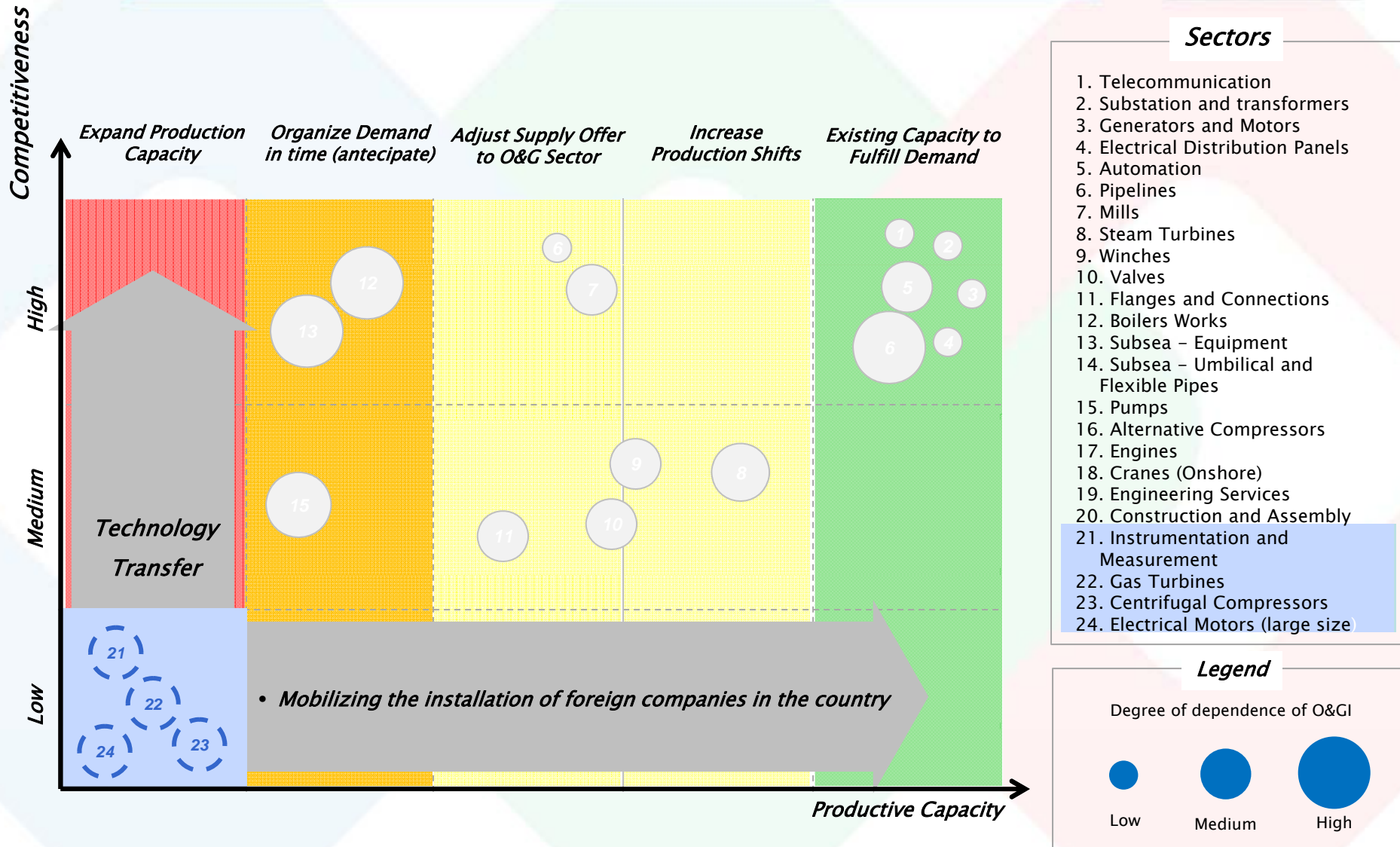

# O&G Demand Driven Industrial Policy

## Concepts and Main Roles



### PIDD - P&G

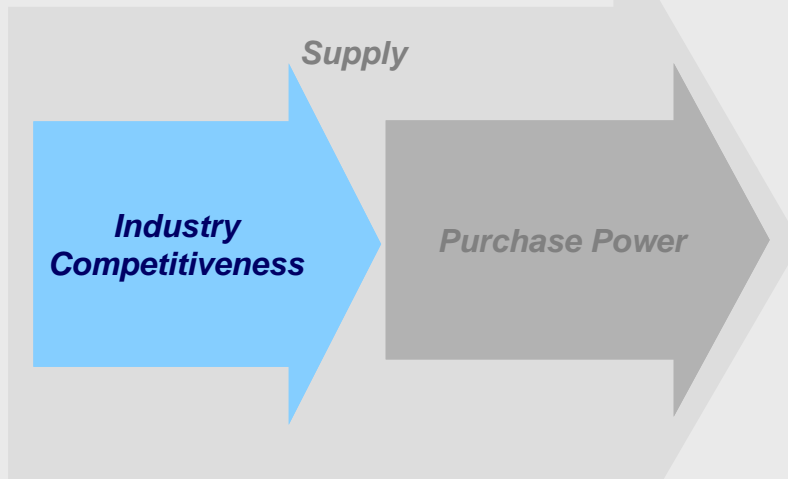

### Sustainability Actions

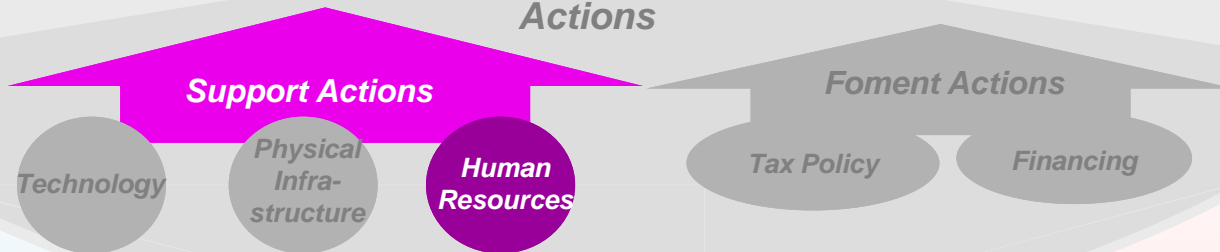

# Professional Qualification Plan

## Concepts



### DIAGNOSIS

### IMPLEMENTATION

#### Projects Portfolio

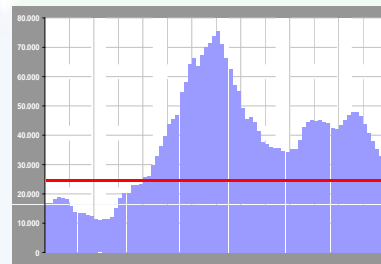
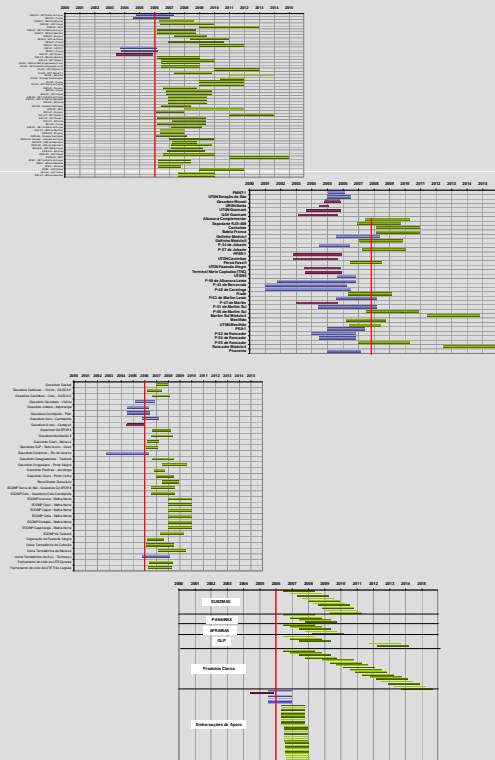

#### Demand by Region



Professionals Categories

#### Regional Demand

Demand RJ State

Demand SP State

Demand BA State

Demand ES State

Demand XX State

MANAGEMENT COMMITTEE OF PQP

# Petrobras Business Plan 2010-2014

## Human Resources Demand - BP 2010-2014



### PROFESSIONALS REQUIRED FOR O&G PORTFOLIO IMPLEMENTATION

**185** PROFESSIONALS CATEGORIES

**212.638** Qualified professionals

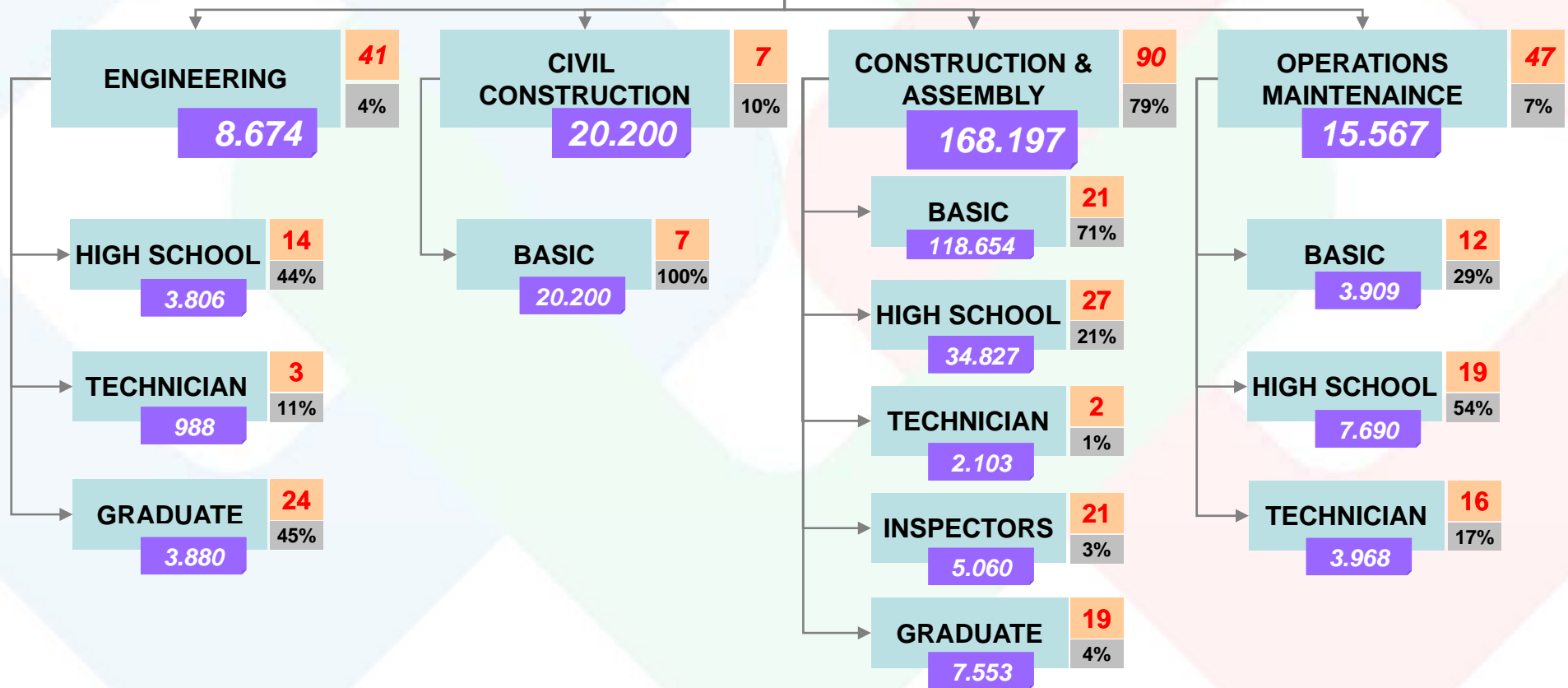

# Petrobras Business Plan 2008-2012

## Human Resources Demand - BP 2008-2012

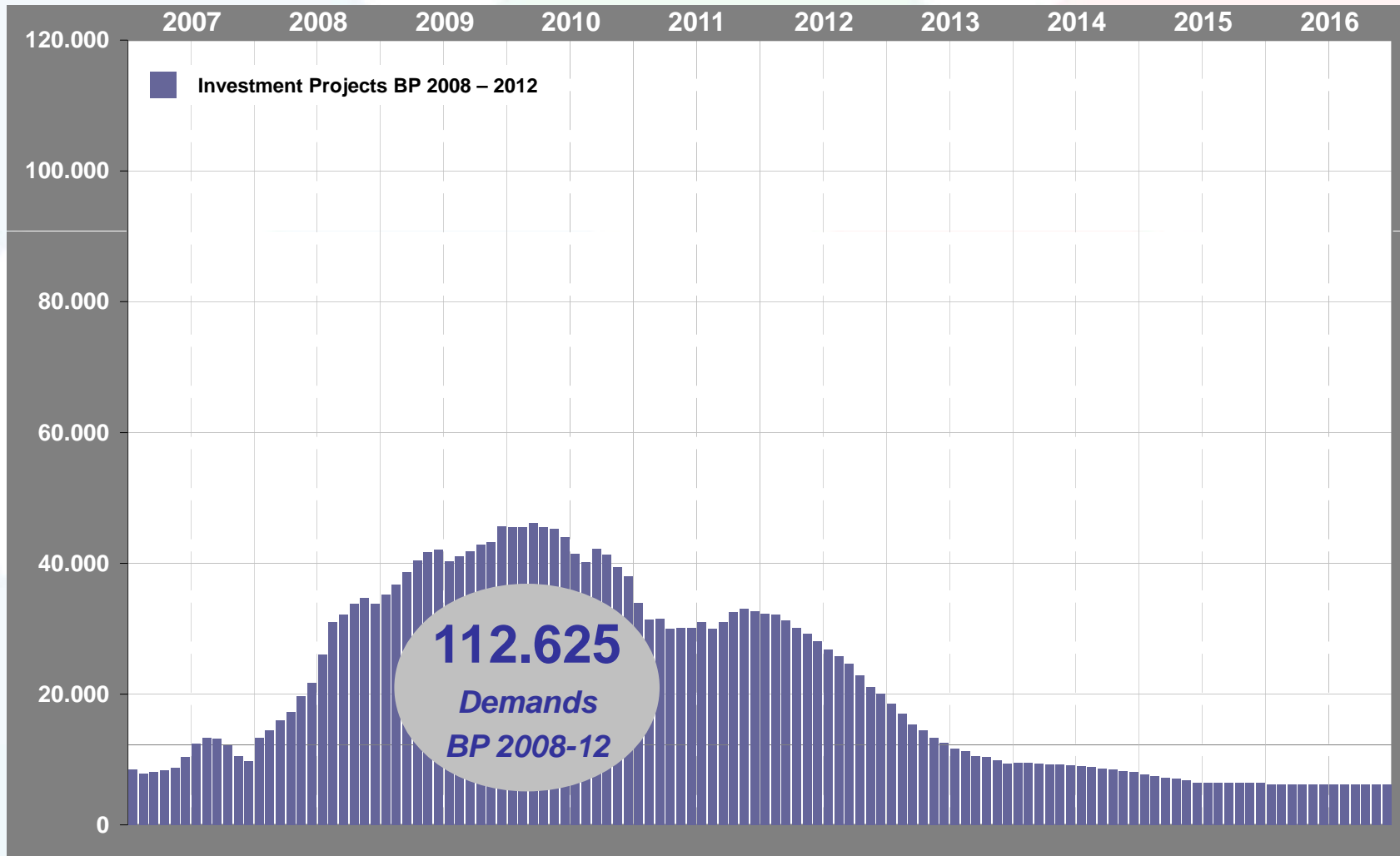

# Petrobras Business Plan 2009-2013

## Human Resources Demand - BP 2009-2013

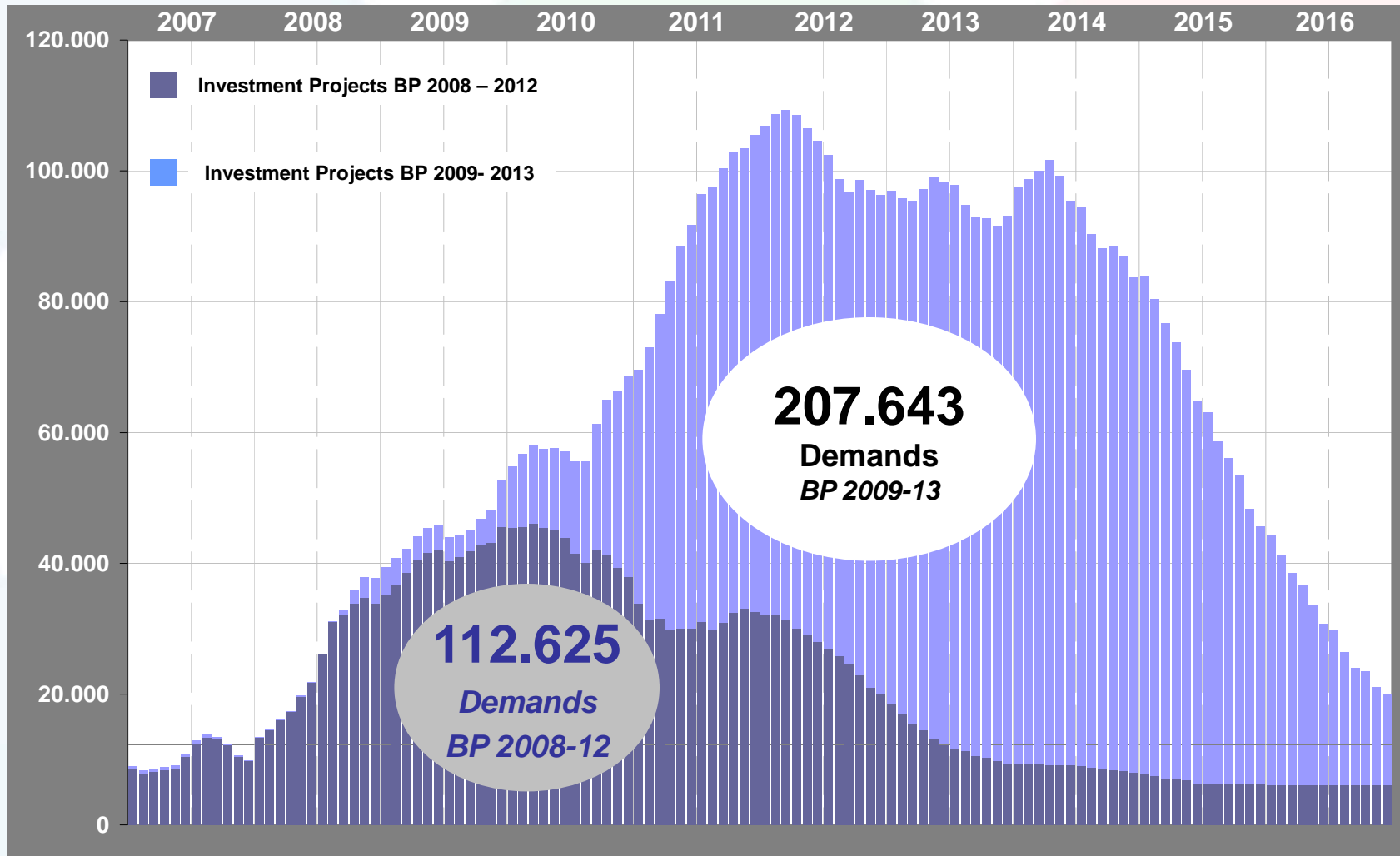



# O&G Demand Driven Industrial Policy

## Competitiveness Support Actions- Financing



### PIDD - P&G

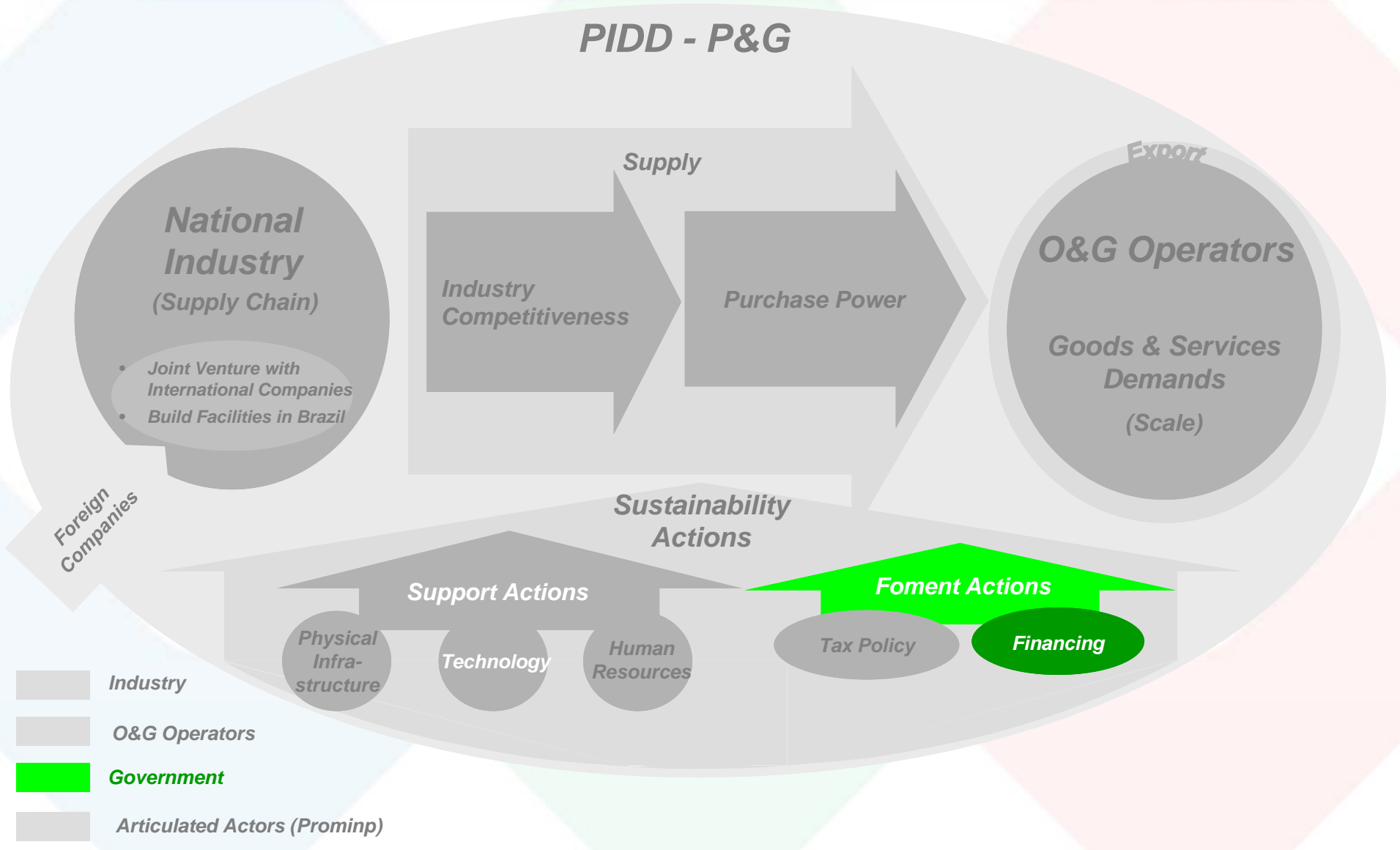

- Industry
- O&G Operators
- Government
- Articulated Actors (Prominp)

# Progridir Petrobras` Supply Chain Financing Program

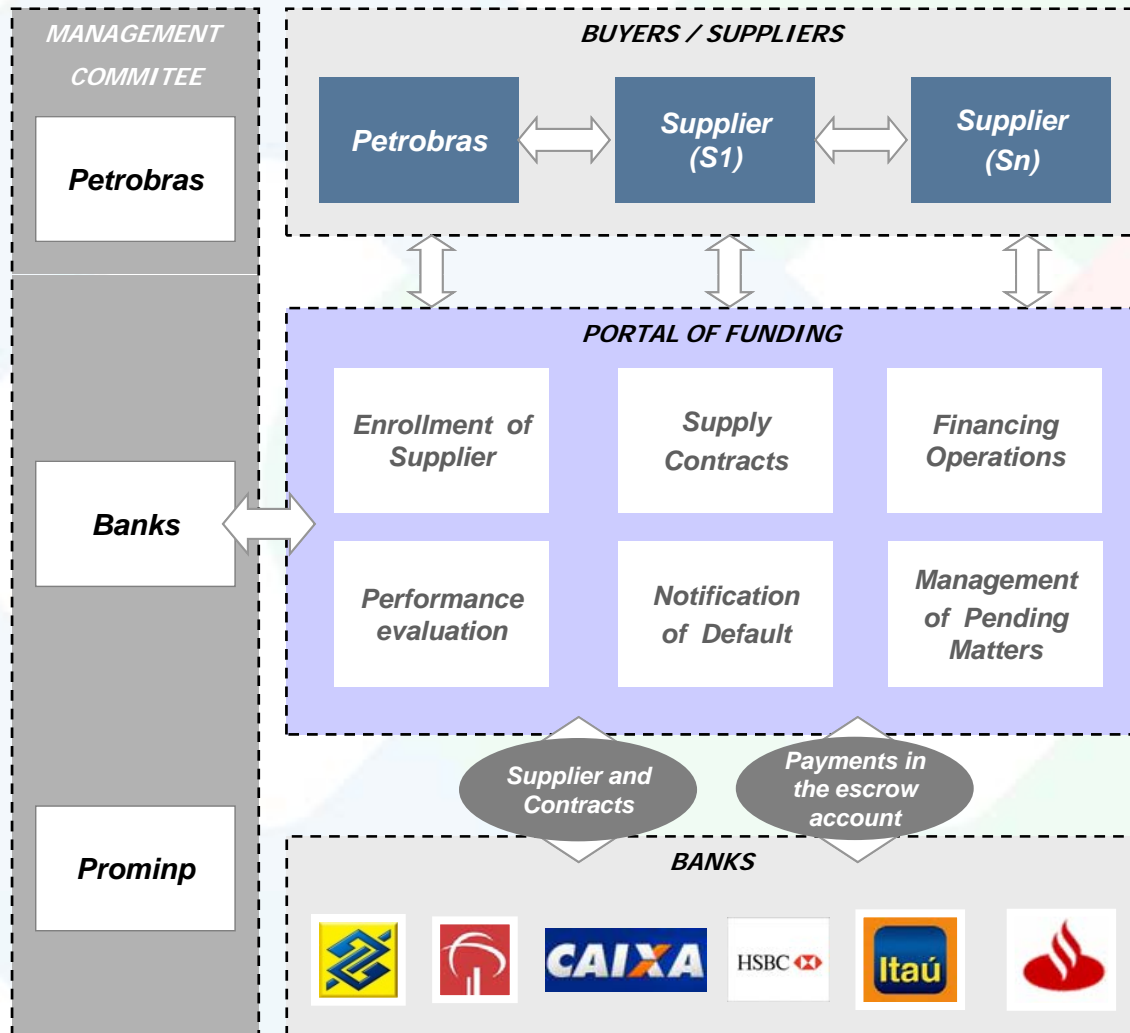

## Program Background

- Access to credit proves a major challenge for Petrobras` supply chain
- A contract with Petrobras means more competitive financing conditions to suppliers
- Progridir was created to extend this benefit (lower credit risk of Petrobras suppliers) to the whole supply chain
- The program promotes a financing reverse bidding process, involving the six largest banks operating in Brazil.

*Thank you for your attention.*

*For more information please visit [www.prominp.com.br](http://www.prominp.com.br)  
or e-mail us at [prominp@petrobras.com.br](mailto:prominp@petrobras.com.br)*



**Agora é assim.  
Tudo que pode ser feito  
no Brasil, tem que ser  
feito no Brasil.**



**Prominp**